

# ***PARTS LIST***

---

## ***TFMX-C*** ***(SINGLE HEAD)***

# Table of Contents

---

● GENERAL VIEW	
● FRAMING.....	MG-1
● MAIN SHAFT DRIVE SYSTEM.....	MG-2
● CYLINDER BED 1.....	MG-3-1
● CYLINDER BED 2.....	MG-3-2
● COLOR CHANGE SYSTEM.....	MG-4
● ARM 1.....	MG-5-1
● ARM 2.....	MG-5-2
● ARM 3.....	MG-5-3
● NEEDLE BAR CASE 1.....	MG-6-1
● NEEDLE BAR CASE 2.....	MG-6-2
● UPPER THREAD HOLDER.....	MG-7
● X-AXIS DRIVE SYSTEM.....	MG-8
● Y-AXIS DRIVE SYSTEM.....	MG-9
● TENSION BASE.....	MG-10
● THREAD STAND.....	MG-11
● OPERATION PANEL.....	MG-12
● ELECTRICAL PARTS.....	MG-13
● UNDER THREAD WINDER (OPTION).....	MG-14

Part Nos. of screws, nuts, washers etc. are listed at the end of volume.

\*Regarding the part number that contains description of @, the part differs depending on model, spec. etc.

\*When you place an order of such a part, please also inform us of your model, embroidery space and manufacturing number of the machine.

<b>Ex.</b>	TFMX-C901	(450×520)S	No.01234
	[Model]	[Emb. Space]	[Mfg. No.]

GENERAL VIEW

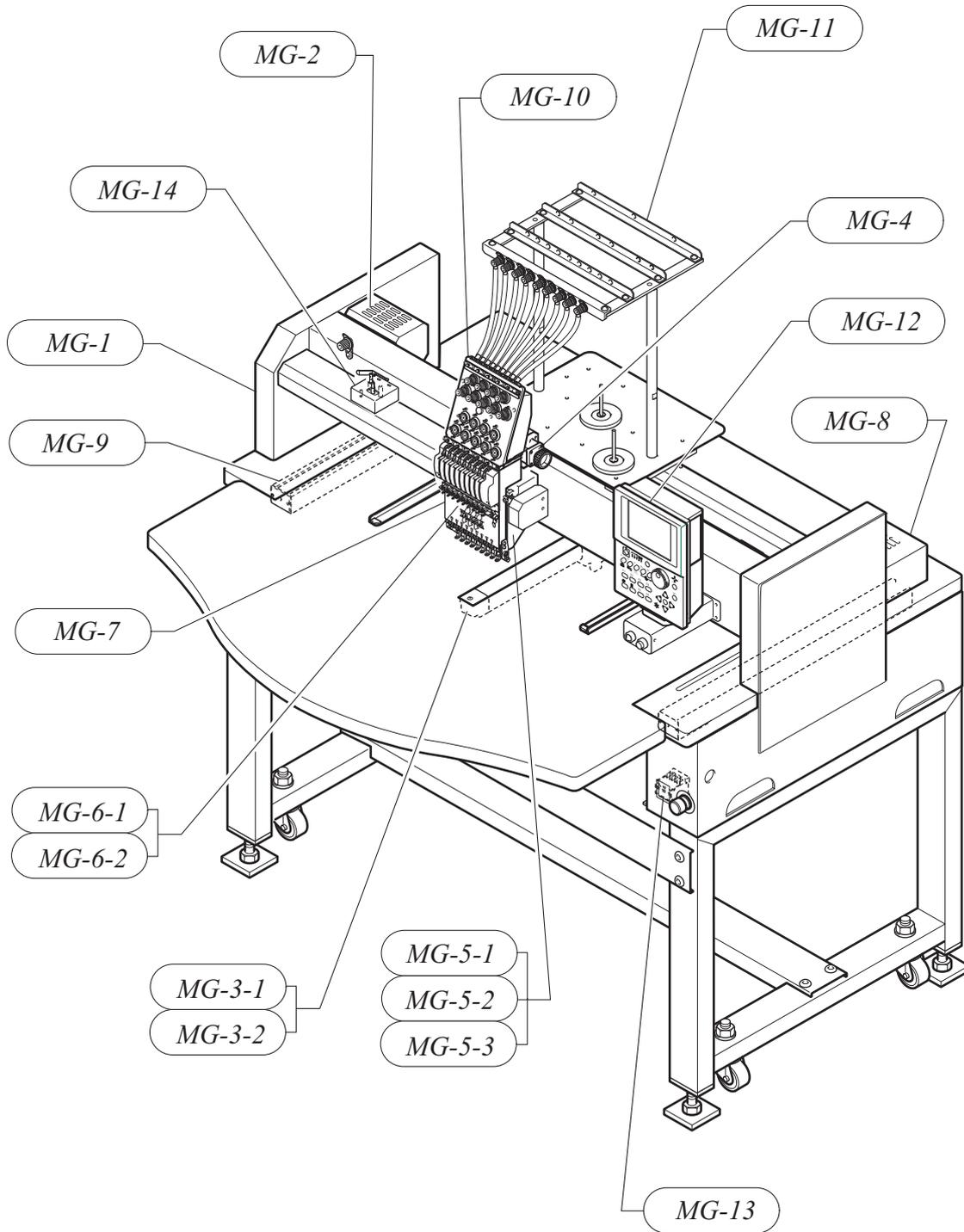

FRAMING

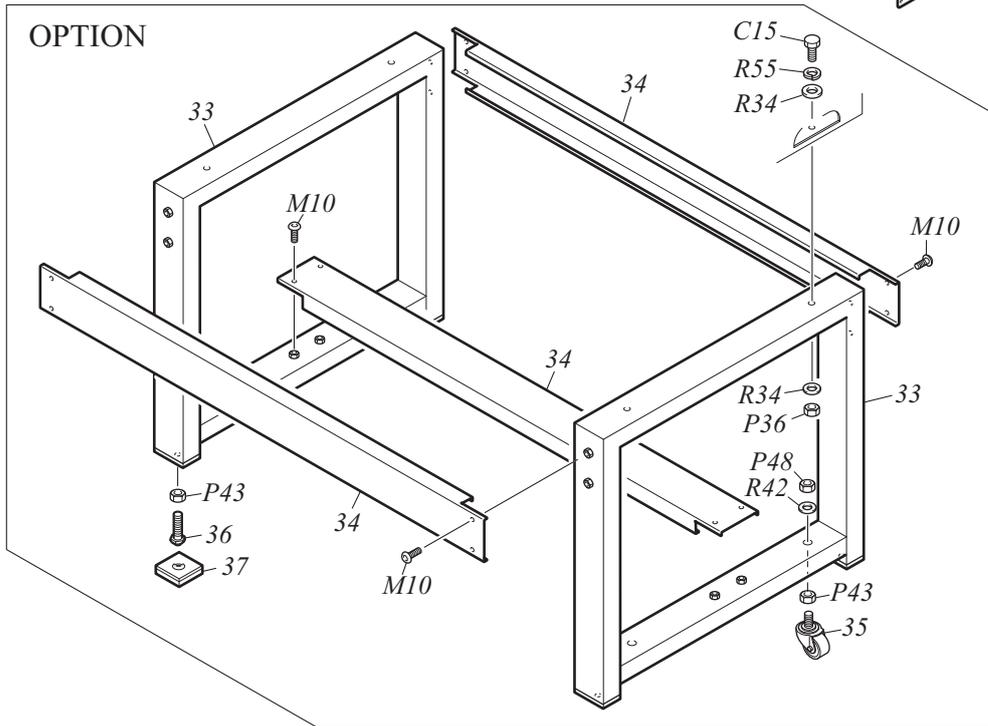
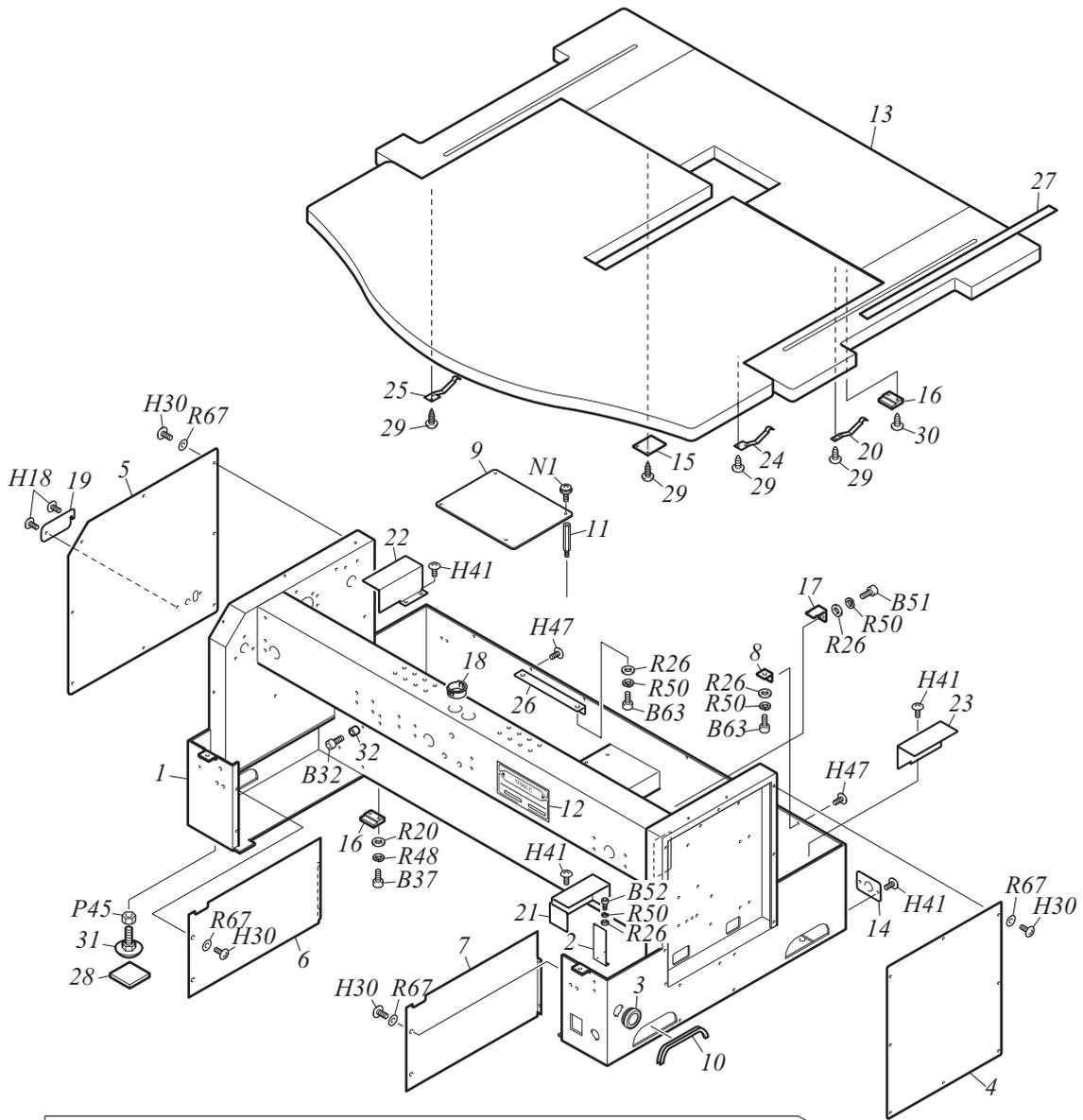

# FRAMING

MG-1

No.	Part Name	Part No.	Remark
1	STAND :0001/045*520S[A]	MS7101010A20	
2	BRACKET :BREAKER	030130150000	
3	GROMMET WITH FILM :26A	644500210000	
4	COVER :RIGHT-SIDE BOX	030440300010	
5	COVER :LEFT-SIDE BOX	030440310000	
6	COVER :STAND :L	03044032L000	
7	COVER :STAND :R	03044032R000	
8	BRACKET :TABLE	030610190000	
9	COVER :DC POWER SUPPLY	0J5100900000	
10	REGULAR TRIM :125MM	617300040000	
11	STUD :NO.1 :M3-70	505103050010	
12	MAIN NAME PLATE :TFMX-C	14S70@@@0010	
13	TABLE :0001/045*520S	2S7100010010	
14	HOLDER HARNESS :A	03014003A010	
15	TABLE HOLDER	030610010010	
16	STOPPER :TABLE	030620030020	
17	STAY :WIRING	0F4160360010	
18	BUSHING :HARNESS	0J1501100010	
19	LID :HANDLE	0L2210010000	
20	PLATE SPRING :T1.5	507815010000	
21	COVER :HANDLE :FRONT	030440100010	
22	COVER :HANDLE :REAR L	03044011L000	
23	COVER :HANDLE :REAR R	03044011R000	
24	PLATE SPRING :T1.5 :L	507815020000	
25	PLATE SPRING :T1.5 :R	507815030000	
26	BRACKET :TABLE :B	030610160010	
27	TRAVERSE SCALE	0P1200020000	
28	VIBRATION-PREVENTIVE RUBBER	030520020000	
29	TRUSS HEAD TAPPING SCREW :4P*16	S530041601SD	
30	TRUSS HEAD TAPPING SCREW :4P*20	S530042001SD	
31	ADJUSTER :55MM DIA.	614300220000	
32	DAMPER RING :4MM DIA.	080320410000	
33	BASE :STAND	0L311001@020	
34	JOINT :STAND BASE	0L3110030000	
35	CASTER :SAR65M	614300140000	
36	LEVELING BOLT :M12*50	030530040000	
37	VIBRATION-PREVENTIVE BASE[S]	03052004@s00	
38			
39			
40			
41			
42			
43			
44			
45			
46			
47			
48			
49			
50			

Note: As for parts with mark @, please follow our instructions on Table of Contents in your parts order.

(OU05)



# MAIN SHAFT DRIVE SYSTEM

MG-2

No.	Part Name	Part No.	Remark
1	SERVO MOTOR :200W	0J6300800000	
2	COVER :MAIN MOTOR	030150170000	
3	TIMING PULLEY :MAIN SHAFT :W15-16	501430150000	
4	FLAT PULLEY :40MM DIA.	501901010030	
5	BEARING :600ZZ	630200050000	
6	SCREW WITH ROLLER PIN :NO.3 :M8	514308050000	
7	E-RING :7MM DIA.	611100100000	
8	TIMING BELT :S5MN :W15-1125/G	623200240000	
9	TIMING PULLEY :B :W15-40	50143303B000	
10	BEARING COLLAR :15MM DIA.	502715040010	
11	BEARING CASE :NO.2 :20MM DIA.[S]	508220060S00	
12	BASE :ANGLE INDICATOR	040420210010	
13	ANGLE INDICATOR	040420230010	
14	BEARING CASE :NO.2 :22MM DIA.[S]	508222020S00	
15	BEARING COLLAR :18MM DIA.	502718010010	
16	TIMING PULLEY :A :W15-40	50143303A000	
17	BEARING CASE :LOWER SHAFT/REGULAR ROTARY HOOK[S]	040140010S00	
17	BEARING CASE :LOWER SHAFT/JUMBO ROTARY HOOK[S]	04014001JS00	
18	CLAMP :5N	644500050000	
19	BRACKET :COVER	030460050010	
20	SHAFT COVER	170180010000	
21	BASE :SENSOR :WITHOUT SPACER	040360040010	
22	BRACKET :SHAFT COVER :B	030460130010	
23	BRACKET :SENSOR	040360020010	
24	CARD :PHOTO-INTERRUPTER	0J4201600020	
25	R. H. BASE CONNECTING SHAFT :15P*558	QS7102020000	
26	MAIN SHAFT :18P*682	QS7101010000	
27	ROTATING DETECTING PLATE[S]	040360050S10	
28	POINTER	040410070010	
29	COVER :TIGHTENING COLLAR	170110080000	
30	TIMING BELT :S3MN :W15-207/G	621300020000	Regular Rotary Hook
30	TIMING BELT :S3MN :W15-201/G	621300010000	Jumbo Rotary Hook
31	BEARING COLLAR :15MM DIA.	502715080000	
32	TIMING PULLEY :W15-30[S]	501237010S00	
33			
34			
35			
36			
37			
38			
39			
40			
41			
42			
43			
44			
45			
46			
47			
48			

Note: As for parts with mark @, please follow our instructions on Table of Contents in your parts order.

(OU05)

CYLINDER BED 1

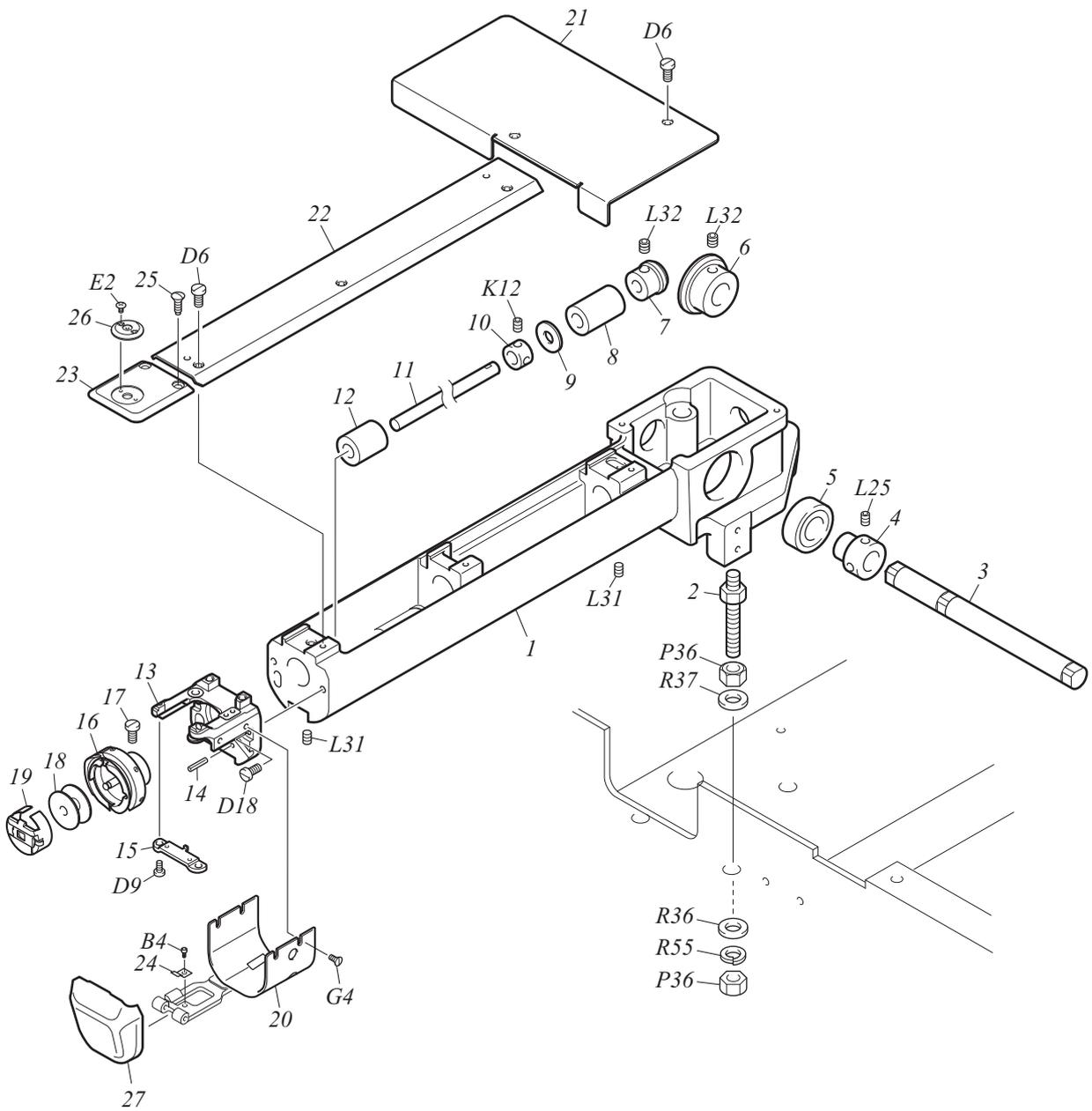

# CYLINDER BED 1

MG-3-1

No.	Part Name	Part No.	Remark
1	CYLINDER BED :NO.1 :REGULAR ROTARY HOOK	05012001A000	
1	CYLINDER BED :NO.1 :JUMBO ROTARY HOOK	05012002A000	
2	ROTARY HOOK BASE STUD	050310110000	
3	R. H. BASE CONNECTING SHAFT :15P*179	QS7102010000	
4	BEARING COLLAR :15MM DIA.	502715080000	
5	BEARING :6003ZZ	630200080000	
6	SPIRAL BEVEL GEAR :NO.1 :28T	506528030000	
7	SPIRAL BEVEL GEAR :NO.1 :14T	506514030000	
8	OIL-BUSHING :NO.1 :7.94MM DIA.	509179090010	
9	PLAIN WASHER :7.94*19*T0.8	519108030000	
10	STOPPER COLLAR :7.94MM DIA.	502107020000	
11	SHAFT :ROTARY HOOK :7.94MM DIA.	050330430000	
12	OIL-BUSHING :NO.1 :7.94MM DIA.	509179020000	
13	NEEDLE PLATE BRACKET	050330460000	
14	SPRING PIN :3*12	611400080000	
15	ROTARY HOOK SUPPORT	050330270020	
16	ROTARY HOOK :REGULAR ROTARY HOOK HSL-ATR (MTQETA)	050210140010	
16	ROTARY HOOK :JUMBO ROTARY HOOK KHS20-RYPOET2	05022005J010	
17	ROTARY HOOK SET SCREW	050290010000	
18	BOBBIN :REGULAR ROTARY HOOK	050260010020	
18	BOBBIN :HSM ALUMINUM FULL HARD ALUMITE	05027002J000	Jumbo Rotary Hook
19	BOBBIN CASE :REGULAR ROTARY HOOK :STANDARD	050240150000	
19	BOBBIN CASE :JUMBO ROTARY HOOK :STANDARD	05025001J000	
20	COVER :NEEDLE PLATE BRACKET	050330510010	
21	COVER :CYLINDER BED :REAR	050330490000	
22	COVER :CYLINDER BED :FRONT	050330450010	
23	NEEDLE PLATE :COMMON USE	050340150010	
24	PLATE SPRING :ROTARY HOOK COVER :T0.2	507802050000	
25	ROUND COUNTERSUNK HEAD SCREW :11/64*8.4B	511554010000	
26	BOSS :COMMON USE NEEDLE PLATE	05034016@020	2.0 to 3.0mm Dia.
27	ROTARY HOOK COVER	050330500020	
28			
29			
30			
31			
32			
33			
34			
35			
36			
37			
38			
39			
40			
41			
42			
43			
44			
45			
46			

Note: As for parts with mark @, please follow our instructions on Table of Contents in your parts order.

(OU05)



# CYLINDER BED 2

MG-3-2

No.	Part Name	Part No.	Remark
1	LEVER SHAFT :KNIFE CONNECTING PLATE[S]	050320850S20	
2	OIL-BUSHING :NO.1 :F81212162	638100370000	
3	LEVER :KNIFE CONNECTING PLATE SHAFT	050321000000	
4	CONNECTING PLATE :KNIFE	050320800010	
5	LEVER SHAFT :KNIFE[S]	050320040S30	
6	THREAD SEPARATING PLATE :DIRECT MOVEMENT 2-BLADE TYPE	050320930000	
7	MOVABLE KNIFE :DIRECT MOVEMENT 2-BLADE TYPE	050320920000	
8	FIXED KNIFE :DIRECT MOVEMENT 2-BLADE TYPE	050320940000	
9	UNDER THREAD PRESSER	050320740000	
10	E-RING :4MM DIA.	611100070000	
11	SOLENOID :OPEN FRAME	640600020021	
12	BRACKET :PICKER SOLENOID	050320540000	
13	COVER :PICKER SOLENOID	050320360010	
14	COMPRESSION SPRING :0.6MM DIA.	507606020010	
15	O-RING :6.8MM DIA.	050320510000	
16	CONNECTING PLATE :PICKER	050320570010	
17	STEPPED SCREW :NO.1 :M2.5*6	512130010000	
18	SHAFT :PICKER	050320750050	
19	E-RING :2MM DIA.	611100050000	
20	PICKER	050320760020	
21	HOLDER :PICKER SHAFT	050320840010	
22	FLAT FILLISTER HEAD SCREW :M6*10	511106010000	
23	STOPPER :PICKER	050320700000	
24	STRAIGHT PIN :NO.1 :3MM DIA.	503101100000	
25	PULSE MOTOR :42MM SQUARE :DOUBLE-END[T]	0J6103800T10	
26	PLASTIC WASHER :6*15*T2	519206010000	
27	BASE :ATH MOTOR	050321020000	
28	DAMPER RING :3MM DIA. E	050320470010	
29	CARD :MAGNETIC SENSOR A	0J4204400000	
30	LEVER :ATH	050320100000	
31	SENSOR PLATE :NO.1	050320110000	
32	CONNECTING PLATE :ATH DRIVE ARM	050320430000	
33	STEPPED SCREW :NO.1 :M4*6.7	512104100040	
34			
35			
36			
37			
38			
39			
40			
41			
42			
43			
44			
45			
46			
47			
48			
49			
50			

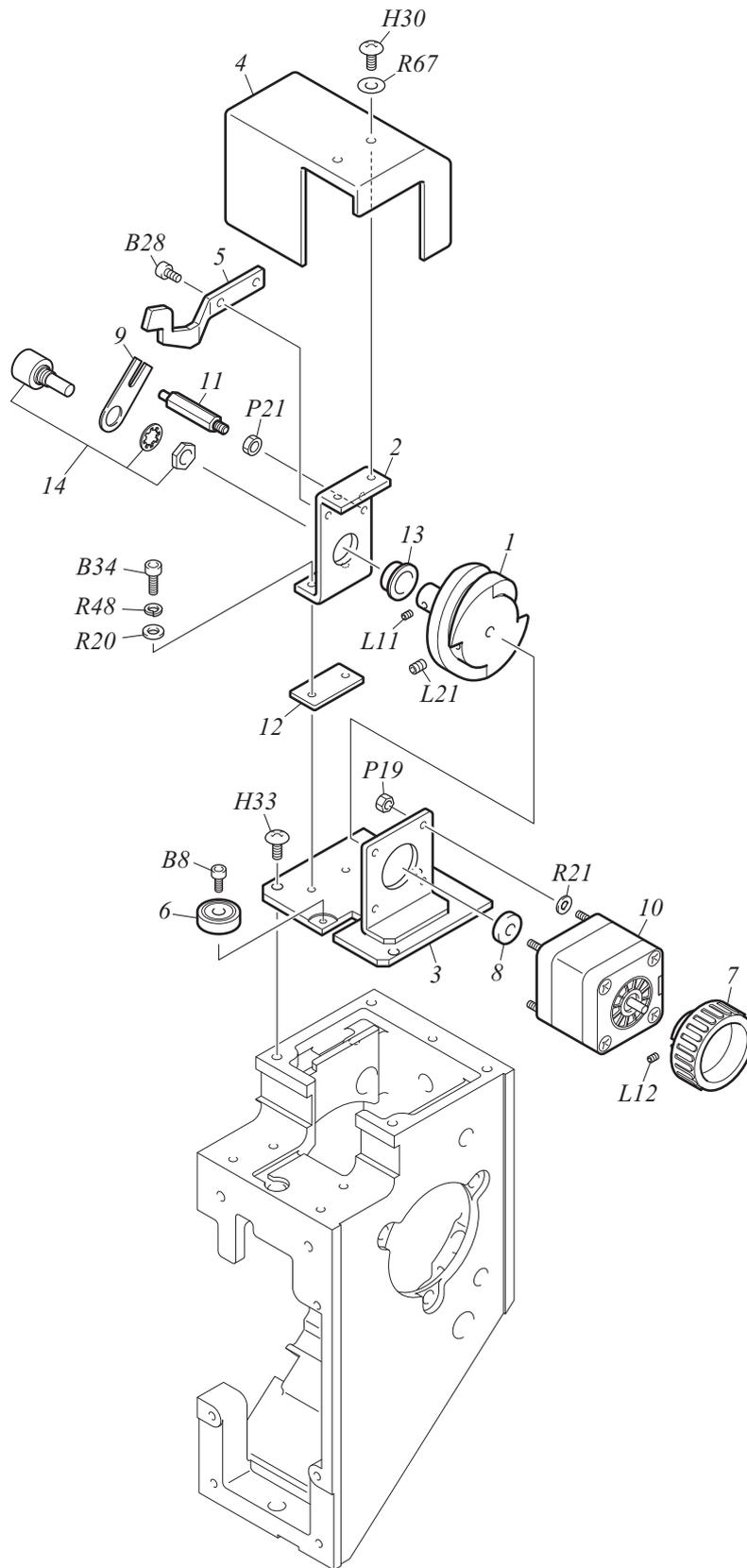

# COLOR CHANGE SYSTEM

MG-4

No.	Part Name	Part No.	Remark
1	CAM :CHANGE	070110030000	
2	BEARING CASE :CHANGE CAM	070110370000	
3	BASE :CHANGE MOTOR	070110340010	
4	COVER :CHANGE	070110350010	
5	SENSOR ARM	0C0230210000	
6	ROLLER PIN[S]	080290040S10	
7	KNOB :B	08052001B010	
8	PLAIN WASHER :5.1*15*T2.3	519106070000	
9	BRACKET :POTENTIOMETER	0C0420020010	
10	PULSE MOTOR :42MM SQUARE :DOUBLE-END	0J6107802000	
11	STUD :NO.4 :M4-27.5	505404030020	
12	SPACER :NO.2 :T3	510200390010	
13	OIL-BUSHING :NO.2 :MB0206-20FDU	638100240000	
14	POTENTIOMETER	640900010001	
15			
16			
17			
18			
19			
20			
21			
22			
23			
24			
25			
26			
27			
28			
29			
30			
31			
32			
33			
34			
35			
36			
37			
38			
39			
40			
41			
42			
43			
44			
45			
46			
47			
48			
49			
50			



# ARM 1

MG-5-1

No.	Part Name	Part No.	Remark
1	HEAD	080120010030	
2	LINEAR WAY :NEEDLE BAR CASE	08025004@000	6 to 15-Needle
3	REINFORCING PLATE	08025005@000	12, 15-Needle
4	HEAD FRONT COVER :L	08042002L000	
5	HEAD FRONT COVER :R	08042002R000	
6	SOLENOID :OPEN FRAME	640600120011	
7	O-RING :S-7	612200120000	
8	E-RING :4MM DIA.	611100070000	
9	O-RING :SS-18	612200150000	
10	E-RING :1.5MM DIA.	611100040000	
11	LEVER :SOLENOID	080270010000	
12	TORSION SPRING :0.5MM DIA.	507305020020	
13	COLLAR :NO.1 :3.1MM DIA.	502505010000	
14	LEVER :DRIVE[S]	080270040S10	
15	GUIDE PLATE :NEEDLE BAR CASE	080250020000	
16	GUIDE BRACKET :NEEDLE BAR CASE	080250030010	
17	SIDE COVER :HEAD :LOWER	080430220000	
18	SIDE COVER :HEAD :UPPER	080430010000	
19	BRACKET :JUMP MOTOR	080320490000	
20	PULSE MOTOR :42MM SQUARE :DOUBLE-END :WITH SCREW BASE	0J6107902000	
21	LEVER :JUMP	080320420010	
22	ROLLER :4.7MM DIA.	515110010010	
23	TORSION SPRING :0.9MM DIA.	507309040020	
24	DAMPER RING :4MM DIA.	080320410000	
25	STEPPED SCREW :NO.1 :9/64*10	512153020000	
26	TAKE-UP LEVER GUIDE RAIL	080280070000	
27	STOPPER :LINEAR WAY	080260120000	
28	FLAT FILLISTER HEAD SCREW :M4*10	511104010010	
29	STEPPED SCREW :NO.1 :11/64*8.2	512154010010	
30	WASHER :4.8*8*T0.8	S301040801KC	
31			
32			
33			
34			
35			
36			
37			
38			
39			
40			
41			
42			
43			
44			
45			
46			
47			
48			
49			
50			

ARM 2

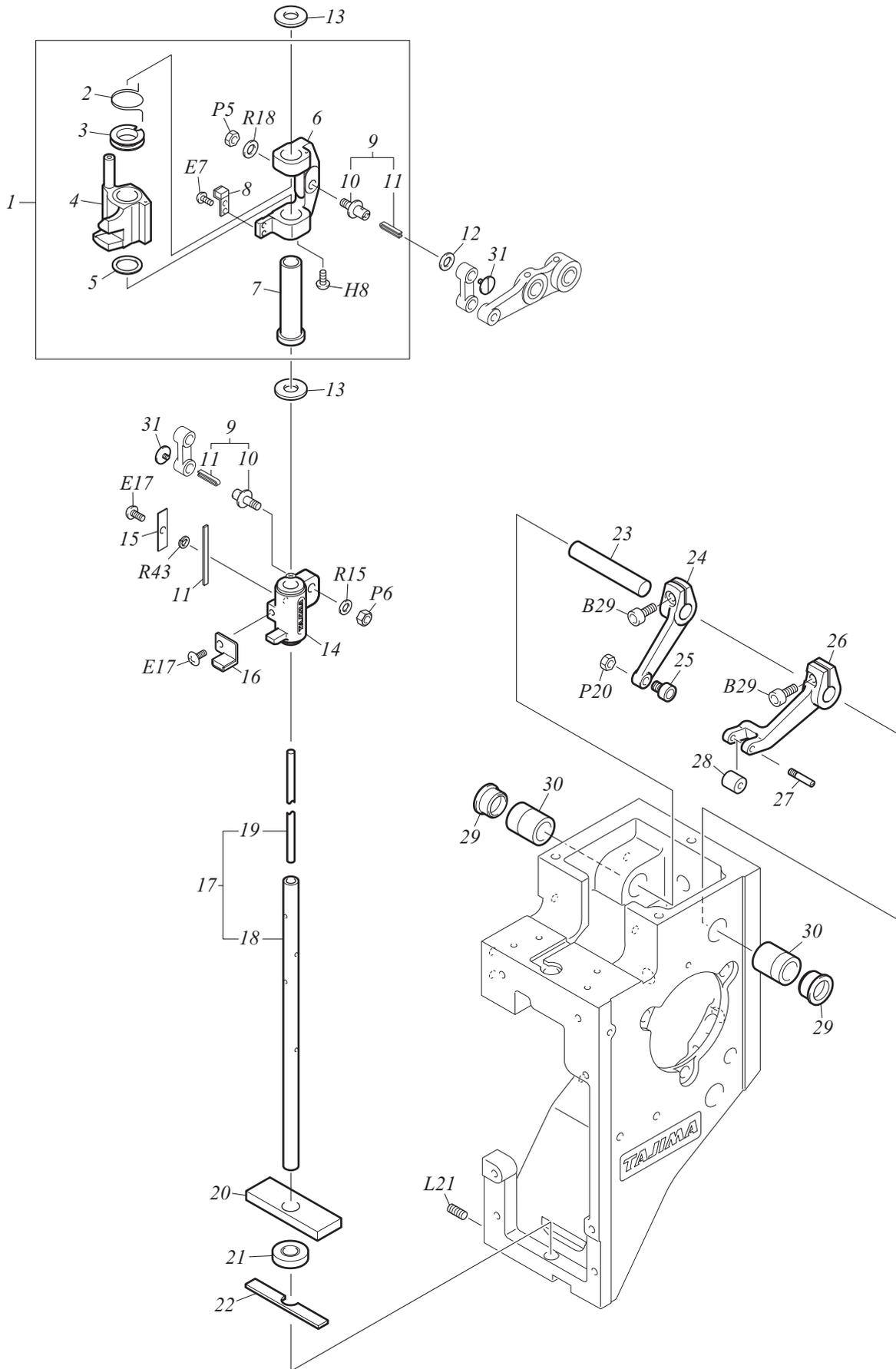

# ARM 2

MG-5-2

No.	Part Name	Part No.	Remark
1	NEEDLE BAR RECIPROCATOR :GN[A]	080210360A40	
2	TORSION SPRING :0.7MM DIA.	507307010010	
3	HOLDER :JUMP SPRING	080210110010	
4	NEEDLE BAR RECIPROCATOR[S]	080210270S40	
5	PLAIN WASHER :10.3*14*T0.5	519112010000	
6	RECIPROCATING SLIDE BLOCK	080210410020	
7	PLASTIC BUSHING :NO.2 :7.24MM DIA.	509472050010	
8	DAMPER BRACKET :NEEDLE BAR RECIPROCATOR	080210090000	
9	SCREW WITH PIN :NO.3 :11/64-7.9[A]	513354060A10	
10	SCREW WITH PIN :NO.3 :11/64-7.9	513354060010	
11	WICK :2.5*1*22	080240120010	
12	PLAIN WASHER :6*9.5*T0.05-0.5	51910604@020	
13	FELT :14MM DIA.	080240060000	
14	PRESSER FOOT RECIPROCATOR :47MM ST[S]	080210420S10	
15	PLATE :PRESSER FOOT RECIPROCATOR	080250060000	
16	DAMPER BRACKET :PRESSER FOOT RECIPROCATOR[S]	080210180S20	
17	NEEDLE BAR DRIVE SHAFT :AUTOMATIC LUBRICATION[S]	0L0210030S00	
18	NEEDLE BAR DRIVE SHAFT :AUTOMATIC LUBRICATION	0L0210030000	
19	WICK :3.5P*183	080240020010	
20	FELT :NEEDLE BAR DRIVE SHAFT :B	080240070000	
21	GUIDE :NEEDLE BAR CASE[S]	080250170S10	
22	FELT :NEEDLE BAR DRIVE SHAFT :D	080240170000	
23	STRAIGHT PIN :NO.1 :8MM DIA.	503101130000	
24	LEVER :TAKE-UP LEVER	080230020000	
25	SCREW WITH ROLLER PIN :NO.7 :M4[S]	514704010S10	
26	ARM :TAKE-UP LEVER	080230060000	
27	SCREW WITH PIN :NO.4 :M3-12.5	513403020000	
28	ROLLER :3MM DIA.	515103010020	
29	LID :TAKE-UP LEVER BEARING CASE :13MM DIA.	080290010000	
30	BEARING CASE BUSHING :NO.1 :8MM DIA.	509508080000	
31	FLAT FILLISTER HEAD SCREW :9/64*4	511153010010	
32			
33			
34			
35			
36			
37			
38			
39			
40			
41			
42			
43			
44			
45			
46			
47			
48			
49			
50			

ARM 3

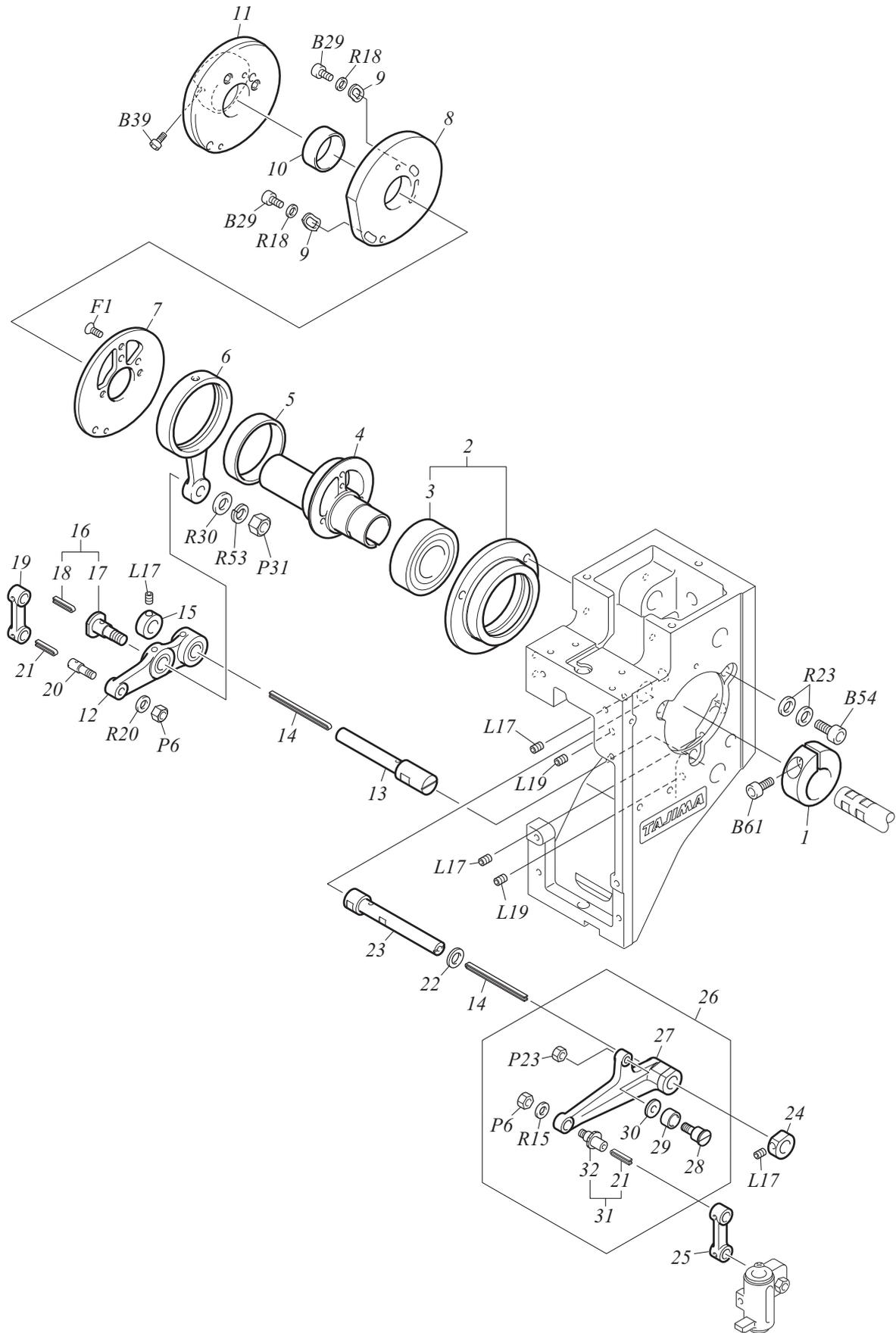

# ARM 3

MG-5-3

No.	Part Name	Part No.	Remark
1	TIGHTENING COLLAR :21MM DIA.	502221010010	
2	BEARING CASE :NO.2 :22MM DIA.[S]	508222010S00	
3	BEARING :60/22ZZ	630200040000	
4	CAM :NEEDLE BAR	080220010000	
5	NEEDLE CAGE :KT404310NE01B2	634400070001	
6	CONNECTING ROD :51.7	080220040000	
7	BASE :TAKE-UP LEVER CAM	080220050000	
8	CAM :TAKE-UP LEVER :REGULAR ROTARY HOOK	080220330000	
8	CAM :TAKE-UP LEVER :JUMBO ROTARY HOOK	080220340000	
9	WASHER :CAM	080220180000	
10	COLLAR :NO.1 :21MM DIA.	502521010000	
11	CAM :PRESSER FOOT[A]	080220021A10	
12	LEVER :NEEDLE BAR[S]	080230050S10	
13	STEPPED PIN :NO.4	503204040020	
14	WICK :3.5P*61	080240040010	
15	STOPPER COLLAR :8MM DIA.	502108020010	
16	STEPPED SCREW :NO.2 :M6*21[S]	512206030S10	
17	STEPPED SCREW :NO.2 :M6*21	512206030010	
18	WICK :3.5*1*34	080240140000	
19	CONNECTING ROD	080230210000	
20	SCREW WITH PIN :NO.3 :11/64-7.7	513354050010	
21	WICK :2.5*1*22	080240120010	
22	PLAIN WASHER :8*15*T0.5	519108050000	
23	STEPPED PIN :NO.4	503204030010	
24	STOPPER COLLAR :8MM DIA.	502108050010	
25	CONNECTING ROD :26	080230010000	
26	LEVER :DRIVE :PRESSER FOOT :47	U8K000000000	
27	LEVER :PRESSER FOOT[S]	080230140S50	
28	STEPPED SCREW :NO.1 :M4*3.8	512104160010	
29	ROLLER :5*8*5	515105020010	
30	PLAIN WASHER :4*7.5*T0.8	519104060000	
31	SCREW WITH ROLLER PIN :NO.4 :11/64E[S]	514454010S00	
32	SCREW WITH ROLLER PIN :NO.4 :11/64E	514454010000	
33			
34			
35			
36			
37			
38			
39			
40			
41			
42			
43			
44			
45			
46			
47			
48			
49			



# NEEDLE BAR CASE 1

MG-6-1

No.	Part Name	Part No.	Remark
1	NEEDLE BAR CASE	09012001@000	
2	NEEDLE BAR	090410020010	
3	COMPRESSION SPRING :0.5MM DIA.	507605030040	
4	FELT PACKING	090430040000	
5	DAMPER RING :F	090430020010	
6	STOPPER :UPPER DEAD POINT	090420040020	
7	FLAT FILLISTER HEAD SCREW :9/64*12	SA41741201UN	
8	NEEDLE BAR CONNECTING STUD	090420060010	
9	COMPRESSION SPRING :0.9MM DIA.	507609030010	
10	PRESSER FOOT CONNECTING STUD	090420020020	
11	PRESSER FOOT[A]	090460230A00	2mm Dia.
11	PRESSER FOOT[A]	090460070A00	3mm Dia. (Thick Thread)
12	PRESSER FOOT	090460230000	2mm Dia.
12	PRESSER FOOT	090460070000	3mm Dia. (Thick Thread)
13	SPLIT COLLAR :PRESSER FOOT	090460040030	
14	FLAT FILLISTER HEAD SCREW :1/8*44	090470020010	
15	DAMPER RING :A	090430070030	
16	NEEDLE CLAMP[S]	090420010S60	
17	SLOTTED HEAD SET SCREW :11/64*6B	511754010010	
18	NEEDLE :DB-K5Z1 #11	616500080000	
19	SPLIT COLLAR :NO.2 :8MM DIA.	502408020010	
19	SPLIT COLLAR :NO.2 :8MM DIA.	502408010020	15-Needle
20	GUIDE SHAFT :TAKE UP LEVER	09033001@000	
21	TAKE-UP LEVER[A]	090310050A20	
22	TAKE-UP LEVER[S]	090310050S20	
23	THREAD GUIDE COLLAR :1.8MM DIA.	516503010010	
24	BOSS :TAKE-UP LEVER	090310040010	
25	SPLIT COLLAR :NO.1 :8MM DIA.	502308020010	
25	SPLIT COLLAR :NO.1 :8MM DIA.	502308010010	15-Needle
26	NEEDLE BAR GUIDE	0904500@@010	
27	RAIL GUIDE	08027006@000	
28	RAIL :CASE :LOWER	09044001@010	
28	RAIL :CASE :LOWER :15-NEEDLE	09044002X010	
29	PARALLEL PIN :4*16-H7	611200050000	
30	SPRING HOOK BAR	09033002@000	
31	LEVER :STOPPER	090320010000	
32	TORSION SPRING :1MM DIA.	507310040010	
33			
34			
35			
36			
37			
38			
39			
40			
41			
42			
43			
44			
45			

Note: As for parts with mark @, please follow our instructions on Table of Contents in your parts order.

(OU05)

NEEDLE BAR CASE 2

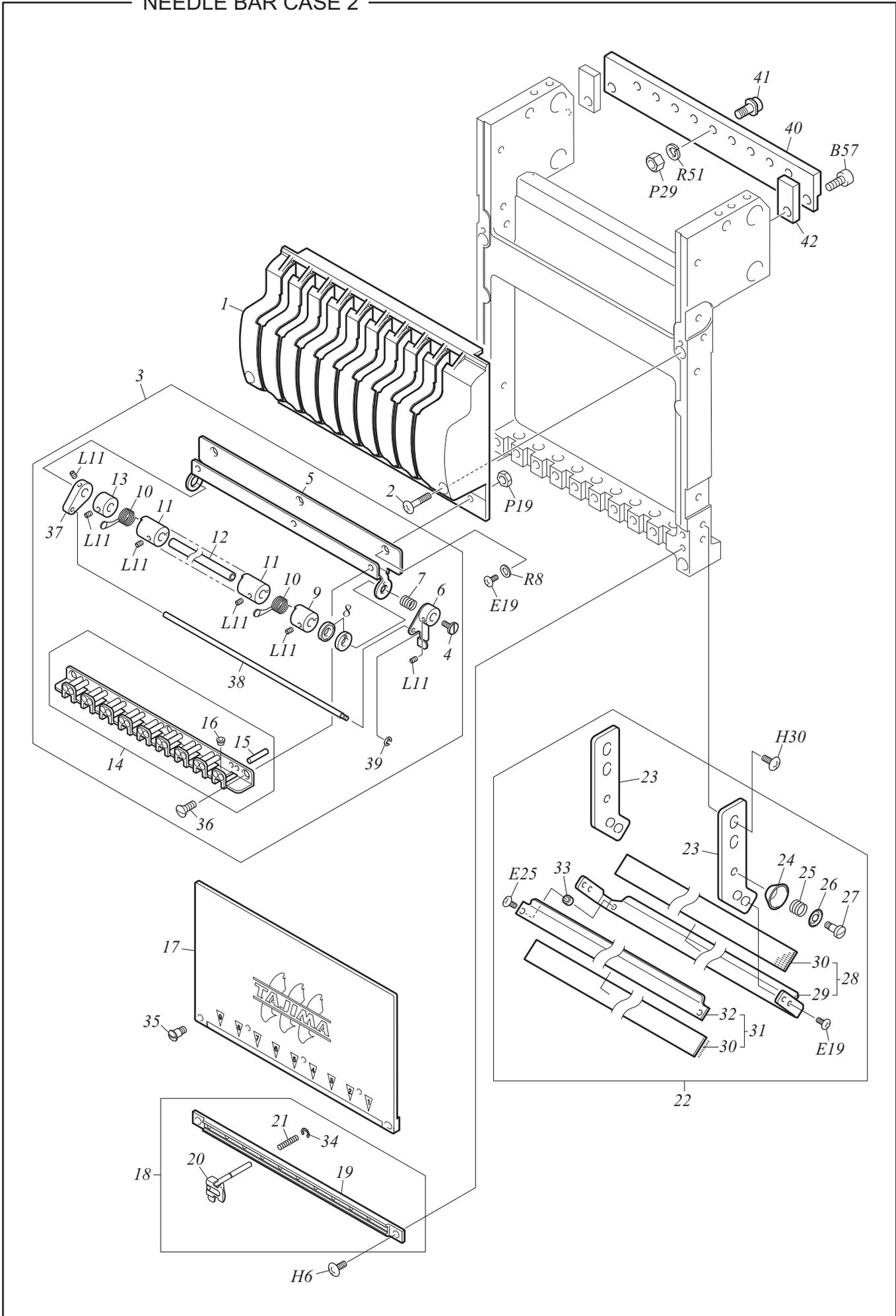

# NEEDLE BAR CASE 2

MG-6-2

No.	Part Name	Part No.	Remark
1	TAKE-UP LEVER COVER	09053002@000	
2	PAN HEAD SCREW :9/64*25	511353010000	
3	ROLLER-TYPE MIDDLE THREAD GUIDE[A]	09021025@A00	
4	FLAT FILLISTER HEAD SCREW :M3*4.3	511103010000	
5	BASE :ROLLER-TYPE MIDDLE THREAD GUIDE	09021025@000	
6	ADJUSTING LEVER[S]	090210140S10	
7	COMPRESSION SPRING :0.7MM DIA.	507607160000	
8	RATCHET	090210050020	
9	TENSION COLLAR :NO.1	090210160010	
10	THREAD TAKE-UP SPRING :NO.2 :0.4MM DIA.	507204010010	
11	TENSION COLLAR :NO.2	090210170010	
12	STRAIGHT PIN :5MM DIA.	09021023@000	
13	STOPPER COLLAR :5MM DIA.	090210180010	
14	ROLLER-TYPE MIDDLE THREAD GUIDE[S]	09021009@S30	
15	STRAIGHT PIN :NO.1 :3MM DIA.	503101150020	
16	THREAD GUIDE COLLAR :1.8MM DIA.	516503010010	
17	FACE PLATE :NEEDLE BAR CASE	09051001@060	
17	FACE PLATE :NEEDLE BAR CASE :15-NEEDLE	09051001X090	
18	UPPER THREAD LOCK[A]	08027005@A00	
19	BASE :UPPER THREAD LOCK	08027005@000	
20	LOCK SHAFT[S]	080270030S00	
21	COMPRESSION SPRING :0.3MM DIA.	507603040030	
22	UPPER THREAD HOLDER[A]	0B020009@A00	
23	BRACKET :UPPER THREAD HOLDER	0B0200010000	
24	THREAD SUSPENDER DISK	0B0200050000	
25	COMPRESSION SPRING :0.3MM DIA.	507603020010	
26	PRESSER :THREAD SUSPENDER SPRING	0B0200060000	
27	STEPPED SCREW :NO.1 :9/64*7.5	512153040000	
28	BASE :UPPER THREAD HOLDER[S]	0B020009@S00	
29	BASE :UPPER THREAD HOLDER	0B020009@000	
30	VELCRO	0B020007@000	
31	UPPER THREAD HOLDER[S]	0B020018@S00	
32	UPPER THREAD HOLDER	0B020018@000	
33	COLLAR :NO.1 :3MM DIA.	502503070010	
34	E-RING :1.5MM DIA.	611100040000	
35	STEPPED SCREW :NO.1 :9/64*8.8	512153150000	
36	ROUND COUNTERSUNK HEAD SCREW :9/64*3.5	511553010010	
37	HOLDER :STRAIGHT PIN	090210190010	
38	STRAIGHT PIN :3MM DIA.	09021022@000	
39	E-RING :2MM DIA.	611100050000	
40	BASE :CHANGE ROLLER	07011006@000	6, 9-Needle
40	BASE :CHANGE ROLLER :12-NEEDLE	07011007Y000	
40	BASE :CHANGE ROLLER :15-NEEDLE	07011008X000	
41	SCREW WITH ROLLER PIN :NO.1 :M5[S]	514105030S20	
42	SPACER BLOCK	070110330000	
43			
44			
45			
46			
47			

Note: As for parts with mark @, please follow our instructions on Table of Contents in your parts order.

(OU05)

UPPER THREAD HOLDER

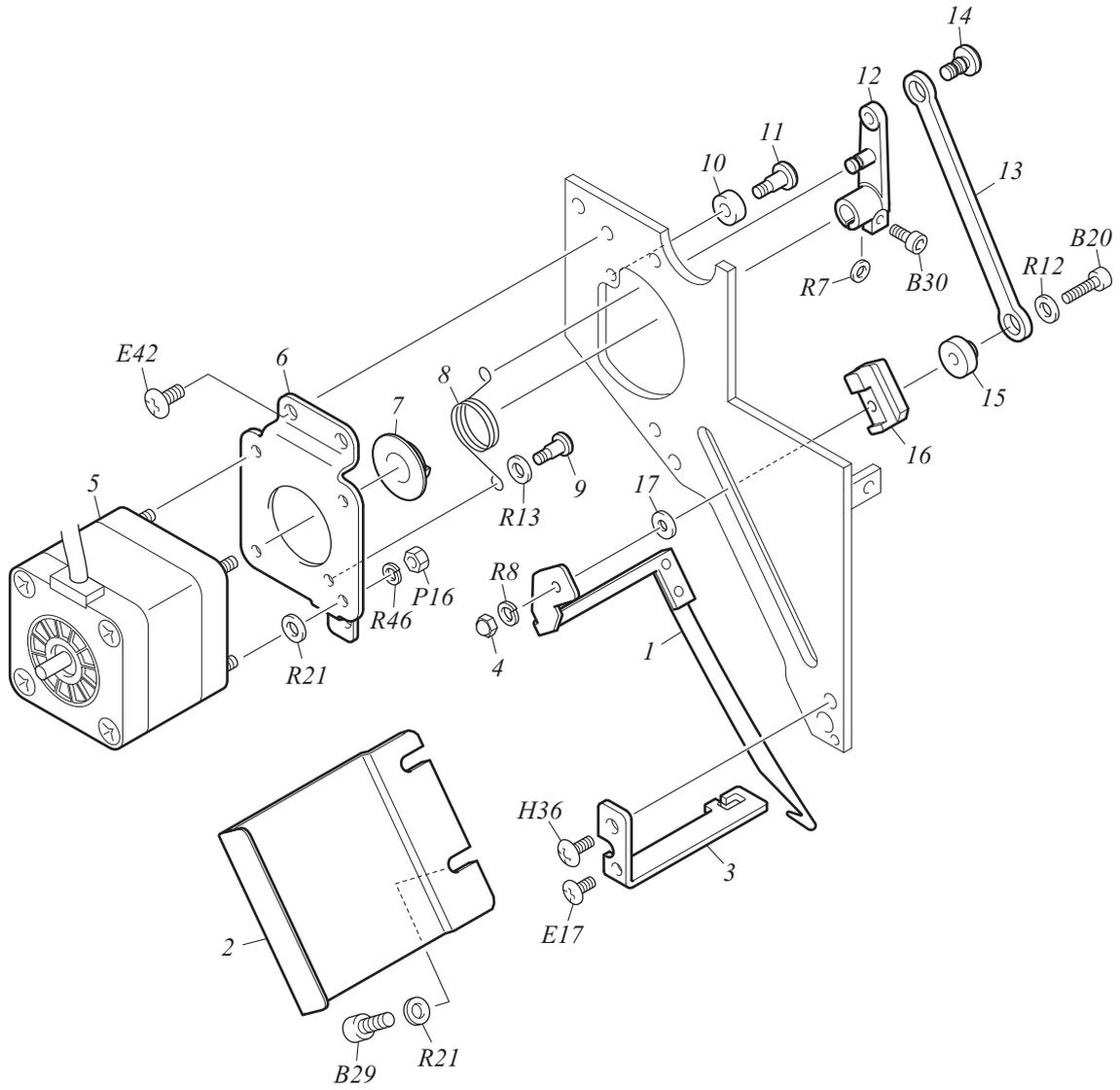

# UPPER THREAD HOLDER

MG-7

No.	Part Name	Part No.	Remark
1	HOOK[S]	0B0110500S30	
2	COVER :HOOK	0B0120010000	
3	GUIDE :HOOK	0B0110520010	
4	HEXAGON CAP NUT :M3	S217030001SD	
5	PULSE MOTOR :42MM SQUARE :DOUBLE-END	0J6107802000	
6	BASE :HOOK MOTOR	0B0110420000	
7	COLLAR :SPRING GUIDE	502522010010	
8	TORSION SPRING :0.8MM DIA.	507308190010	
9	STEPPED SCREW :NO.1 :9/64*7.5	512153040000	
10	DAMPER RING :4MM DIA.	080320410000	
11	STEPPED SCREW :NO.1 :9/64*10	512153020000	
12	LEVER :HOOK	0B0110470000	
13	CONNECTING PLATE :HOOK	0B0110080010	
14	STEPPED SCREW :NO.1 :M4*6.7	512104100040	
15	SPACER :SLIDE HOOK	0B0110370010	
16	SLIDE :HOOK	0B0110510000	
17	WASHER :2.6*7*T0.5	519204010000	
18			
19			
20			
21			
22			
23			
24			
25			
26			
27			
28			
29			
30			
31			
32			
33			
34			
35			
36			
37			
38			
39			
40			
41			
42			
43			
44			
45			
46			
47			
48			
49			
50			



# X-AXIS DRIVE SYSTEM

MG-8

No.	Part Name	Part No.	Remark
1	Z-SPEC. FRAME :0001/520S	0F4110042000	
2	BRACKET :X MOTOR	0F5300370000	
3	COVER :X MOTOR	0F4150170000	
4	STAY :X MOTOR COVER	0F4150180000	
5	BEARING CASE :NO.4 :8MM DIA.[S]	0F4150190S00	
6	PULSE MOTOR :60MM SQUARE :WITH SENSOR[A]	0J6105400A10	
7	FRAME HOLDER	0F4120030030	
8	LINEAR WAY :LWL-15C2R970	660300070000	
9	TIMING BELT :MA5 :W15-299E/LY	623A00020000	
10	BELT CATCHER :NO.1 :X	0F4160480000	
11	BELT CATCHER :NO.2 :X	0F4160490000	
12	SENSOR PLATE :NO.1	0F4140030000	
13	BRACKET :MAGNETIC SENSOR	0F4140020000	
14	CARD :MAGNETIC SENSOR A	0J4204400000	
15	TIMING PULLEY :W15-16	501430140020	
16	TIMING PULLEY :W15-16[S]	501430060S10	
17	HOLDER :TIMING PULLEY	0F4160040000	
18	TENSIONER :X DRIVE BELT	0F4160050010	
19	FLANGE PIN :NO.3	503503030000	
20	RULON WASHER :TW-1020	638400090000	
21	E-RING :7MM DIA.	611100100000	
22	BRACKET :Z-SPEC. FRAME DRIVE BASE :R	0G028012R010	
23	BRACKET :Z-SPEC. FRAME DRIVE BASE :L	0G028012L010	
24	MINI CLAMP :MB-2	644100080000	
25	FRAME HOLDER :L[S]	0G314009LS30	
26	HEXAGON SOCKET HEAD FLANGE SCREW :M5*10	S123051001MZ	
27	FRAME HOLDER :R[S]	0G314009RS30	
28	STOPPER :NO.1	0G314001A020	
29	STOPPER :NO.2	0G314002B020	
30	PLATE SPRING :HOLDER BASE :T1.5	507815060010	
31	COVER :Z-SPEC. FRAME :0001/520S	0F4110130000	
32	TRAVERSE SCALE	0P1200020000	
33	BORDER FRAME :0001/045*520S[A]	309152030A00	
34	BORDER FRAME CLIP :BFF6	0G052007@040	
35			
36			
37			
38			
39			
40			
41			
42			
43			
44			
45			
46			
47			
48			
49			
50			

Note: As for parts with mark @, please follow our instructions on Table of Contents in your parts order.

(OU05)



# Y-AXIS DRIVE SYSTEM

MG-9

No.	Part Name	Part No.	Remark
1	BRACKET :Y-DRIVE BASE	0F4220040000	
2	SENSOR PLATE :NO.1[S]	0F4230370S00	
3	Z-SPEC. FRAME ARM :L	0F423038L000	
4	Z-SPEC. FRAME ARM :R	0F423038R000	
5	DRIVE BASE :NO.7 :L :Y450	16071008L000	
6	DRIVE BASE :NO.7 :R :Y450	16071008R000	
7	BRACKET :Y-DRIVE BASE	030610020000	
8	BELT CATCHER :NO.1 :Y	0F4160070000	
9	HOLDER :TIMING PULLEY	0F4210010010	
10	BELT CATCHER :NO.2 :Y	0F4230160010	
11	SIDE COVER :Y-DRIVE BASE	0F4230220000	
12	BRACKET :ORIGIN SENSOR	0F4230250010	
13	TABLE HOLDER :FRONT L	15212003L000	
14	TABLE HOLDER :FRONT R	15212003R000	
15	TIMING PULLEY :W15-16	501430020020	
16	TIMING PULLEY :W15-16[S]	501430060S10	
17	BEARING COLLAR :12MM DIA.	502712020000	
18	STRAIGHT PIN :NO.4 :10MM DIA.	503104060010	
19	SHAFT :Y-AXIS PULLEY	0F0170110010	
20	E-RING :7MM DIA.	611100100000	
21	TIMING BELT :MA5 :W15-261E/LY	623A00010000	
22	RULON WASHER :TW-1020	638400090000	
23	LINEAR WAY :LWL-15C2R580	660300050000	
24	CARD :MAGNETIC SENSOR A	0J4204400000	
25	BASE :Y MOTOR	0F4240010000	
26	TIMING PULLEY :W19-18	501F18010010	
27	BEARING CASE :NO.3 :15MM DIA.[S]	508315030S00	
28	BRACKET :Y MOTOR	0F4240020000	
29	BEARING COLLAR :12MM DIA.	502712020000	
30	PULSE MOTOR :60MM SQUARE :WITH SENSOR[A]	0J6105400A10	
31	Y SHAFT :12P*924	QS7103010010	
32	TIMING PULLEY :W20-63	501F17010000	
33	TIGHTENING JOINT :12MM DIA.	504312010010	
34	TIMING BELT :3GT :19*270/E	628300010001	
35			
36			
37			
38			
39			
40			
41			
42			
43			
44			
45			
46			
47			
48			
49			
50			

TENSION BASE

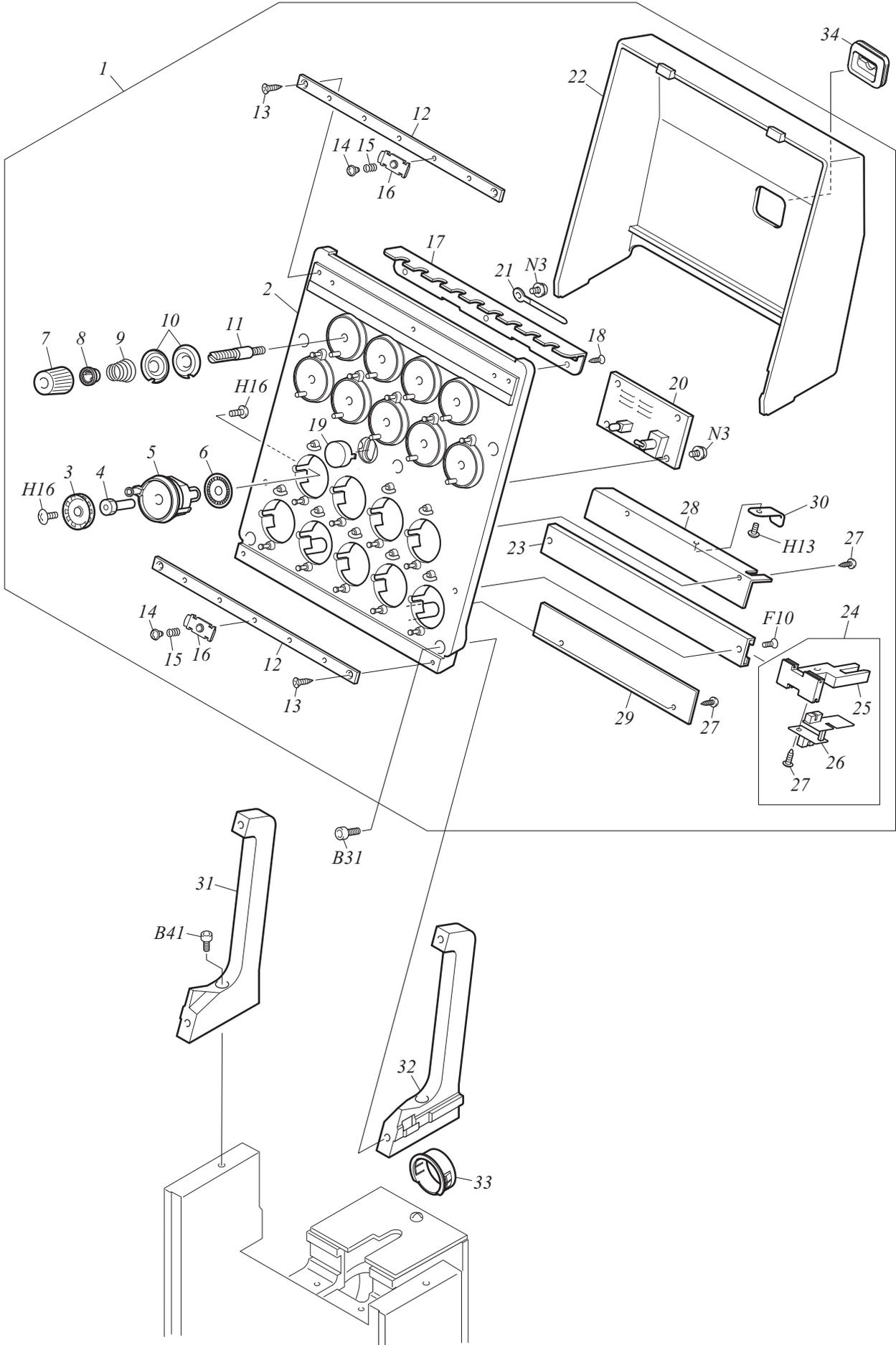

# TENSION BASE

MG-10

No.	Part Name	Part No.	Remark
1	TENSION BASE :ROTARY :TFMX :1ST HEAD	UC29@0000130	
2	TENSION BASE :ROTARY[S]	0C012002@S50	
3	ROTARY TENSION DISK	0C0230120010	
4	SHAFT :ROTARY TENSION DISK	0C0230130030	
5	BASE :ROTARY TENSION DISK[S]	0C0230190S20	
6	SLIT PLATE :ROTARY DISK :50	0J4203800000	
7	KNOB :THREAD TENSION :A	0C0220150000	
8	SPRING HOOK	0C0220080000	
9	TAPER SPRING :0.6MM DIA.	507706010000	
10	TENSION DISK	0C0210020000	
11	THREAD TENSION STUD	0C0210010010	
12	BASE :THREAD PRESSER	0C022018@010	
13	COUNTERSUNK TAPPING SCREW :3P*10	S550031001SD	
14	TRUSS HEAD SCREW :STEPPED :M3*4*2	S132030401TD	
15	TAPER SPRING :0.2MM DIA.	507702010000	
16	THREAD PRESSER	0C0220030010	
17	UPPER THREAD GUIDE :TENSION BASE	0C022017@020	
18	COUNTERSUNK TAPPING SCREW :3P*8	S550030801SD	
19	LAMP COVER :TENSION BASE	0C0250050000	
20	CARD :TENSION BASE	0J2601900010	
21	COATED CLIP :5	644500150000	
22	COVER :TENSION BASE	0C015002@000	
23	RAIL :THREAD BREAKAGE SENSOR	0C023014@000	
24	TC SENSOR[A]	0J2602300A20	
25	BRACKET :TC SENSOR CARD	0C0230220010	
26	CARD :TC SENSOR	0J2602100010	
27	TRUSS HEAD TAPPING SCREW :3P*6	S530030601SD	
28	DISK GUARD :A	0C023020@010	
29	DISK GUARD :B	0C023016@000	
30	PLATE SPRING :T0.3	507803050000	
31	BRACKET :TENSION BASE :L[S]	0C024003LS00	
32	BRACKET :TENSION BASE :R[S]	0C024003RS00	
33	BUSHING :HARNESS	0J1501100010	
34	GROMMET	0C0250090000	
35			
36			
37			
38			
39			
40			
41			
42			
43			
44			
45			
46			
47			
48			
49			
50			

THREAD STAND

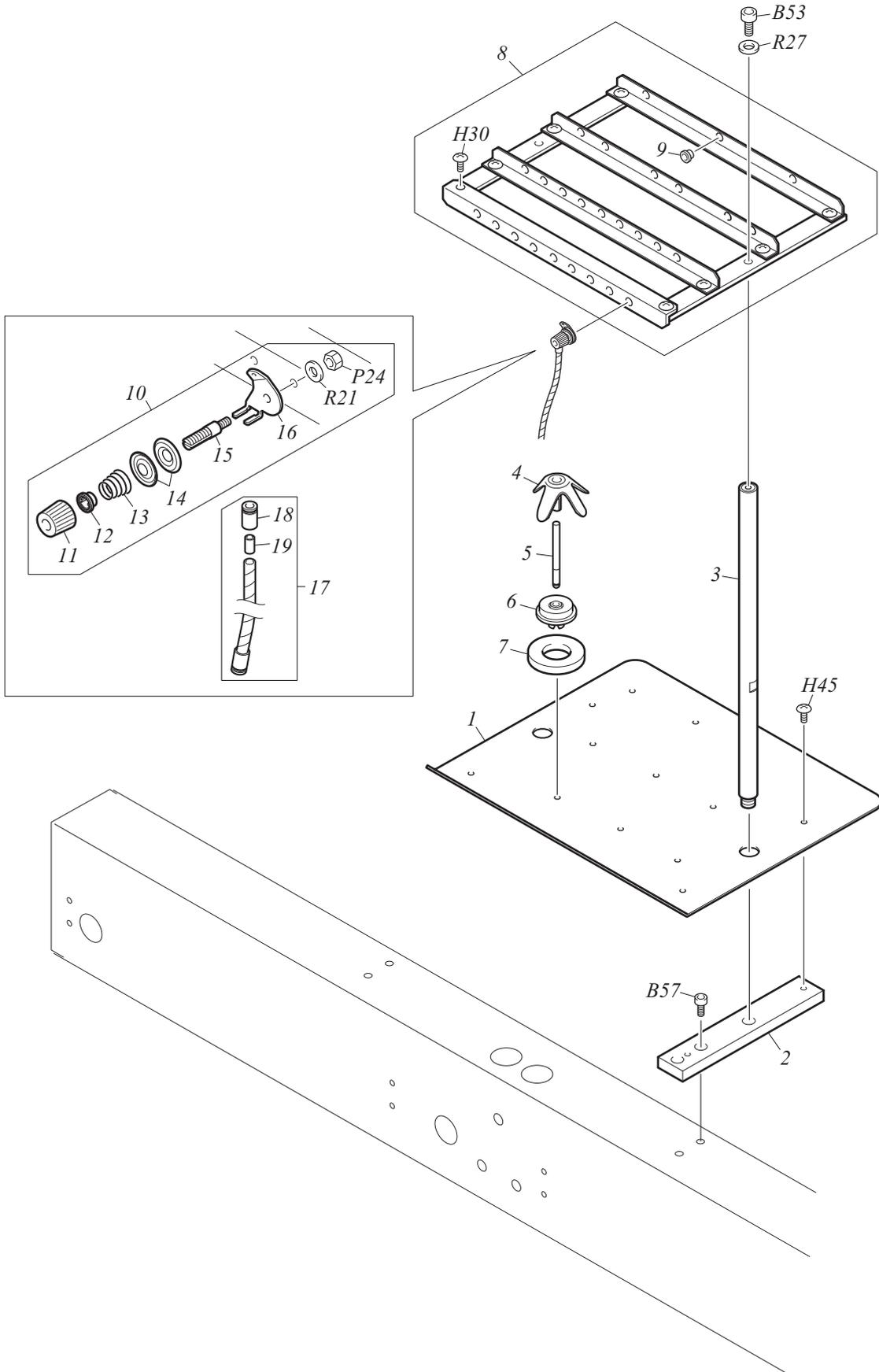

# THREAD STAND

MG-11

No.	Part Name	Part No.	Remark
1	THREAD STAND PLATE	1D810001@010	
2	BASE :THREAD STAND PLATE	0D0110340000	
3	THREAD COURSE SUPPORT BAR :L395	0D0210315010	
4	THREAD STAND BLADE	0D0110010010	
5	THREAD STAND STUD	0D0110410000	
6	BASE :THREAD STAND STUD	0D0110420000	
7	FELT :THREAD STAND PLATE :T10	0D0110022000	
8	THREAD COURSE[A]	1E810001@A10	
9	THREAD GUIDE COLLAR :RED :4MM DIA.	516501011000	
9	THREAD GUIDE COLLAR :BLACK :4MM DIA.	516501012000	
10	THREAD TENSION :TUBE	UD1100000000	
11	KNOB :THREAD TENSION :A	0C0220150000	
12	SPRING HOOK	0C0220080000	
13	TAPER SPRING :0.6MM DIA.	507706010000	
14	TENSION DISK	0C0220160010	
15	THREAD TENSION STUD	0C0210010010	
16	THREAD TENSION GUIDE :TUBE	0D0210150020	
17	SPIRAL TUBE :L230[A]	0D0210052A00	
18	JOINT :SPIRAL TUBE	0D0210130000	
19	COLLAR :NO.1 :5MM DIA.	0D0210140010	
20			
21			
22			
23			
24			
25			
26			
27			
28			
29			
30			
31			
32			
33			
34			
35			
36			
37			
38			
39			
40			
41			
42			
43			
44			
45			
46			
47			
48			
49			

OPERATION PANEL

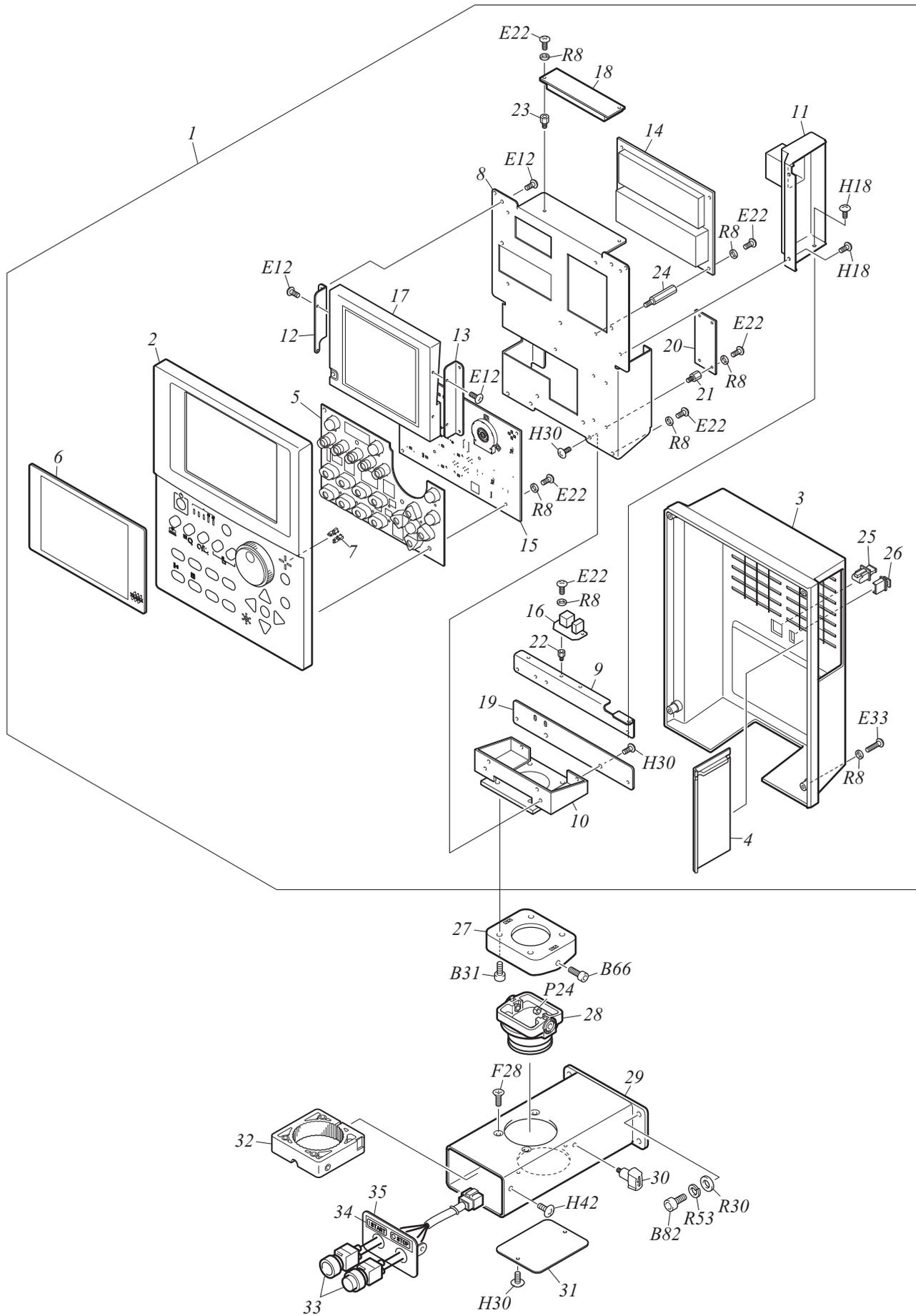

# OPERATION PANEL

MG-12

No.	Part Name	Part No.	Remark
1	CONTROLLER :X16-J[A]	0J0204000A10	Japanese
1	CONTROLLER :X16-E[A]	0J0204001A10	English
2	OPERATION PANEL :FRONT[S]	0J1404200S20	
3	OPERATION PANEL :REAR	0J1404300010	
4	SHUTTER :FDD	0J1404400010	
5	OPERATION BUTTON	0J1404500000	
6	COVER :LCD PANEL	0J1404600010	
7	COVER :LAMP	0J1404700000	
8	BASE :CARD	0J1407600000	
9	SUPPORT :CARD BASE	0J1406500020	
10	BASE :OPERATION PANEL[S]	0J1405000S00	
11	COVER :USB	0J1408500000	
12	BRACKET :LCD :L	0J14077L0000	
13	BRACKET :LCD :R	0J14077R0000	
14	CARD :CPU-J :X16[A]	0J2304802A10	Japanese
14	CARD :CPU-E :X16[A]	0J2304803A10	English
15	CARD :SWITCH	0J3502000010	
16	CARD :I/F CONNECTOR	0J3200700010	
17	LCD :6.5 INCH	641200140000	
18	INVERTER :BACKLIGHT	645500160000	
19	SUPPORT :PANEL BASE	0J1406600020	
20	CARD :CAPACITOR	0J3502600010	
21	SPACER :HEXAGON	644500880000	
22	SPACER :HEXAGON	644500300000	
23	SPACER :HEXAGON	644500360000	
24	SPACER :HEXAGON :BSB-320	644500620000	
25	DUST CAP :LAN	644501340000	
26	DUST CAP :USB	644500490000	
27	BASE :CONTROLLER	030220590000	
28	HOLDER :CONTROLLER	030220580000	
29	PIPE :CONTROLLER	030210300010	
30	KNOBBED SCREW :NO.2 :M5*9[S]	511F05080S10	
31	COVER :CONTROLLER	030210310000	
32	CLAMP :CONTROLLER HOLDER[S]	030220870S00	
33	SWITCH :CYLINDER HEAD[A]	0J0603300A10	
34	IO LABEL :START/STOP	0P0600030000	
35	BASE :START SWITCH/STOP SWITCH[S]	030230190S10	
36			
37			
38			
39			
40			
41			
42			
43			
44			
45			
46			
47			
48			

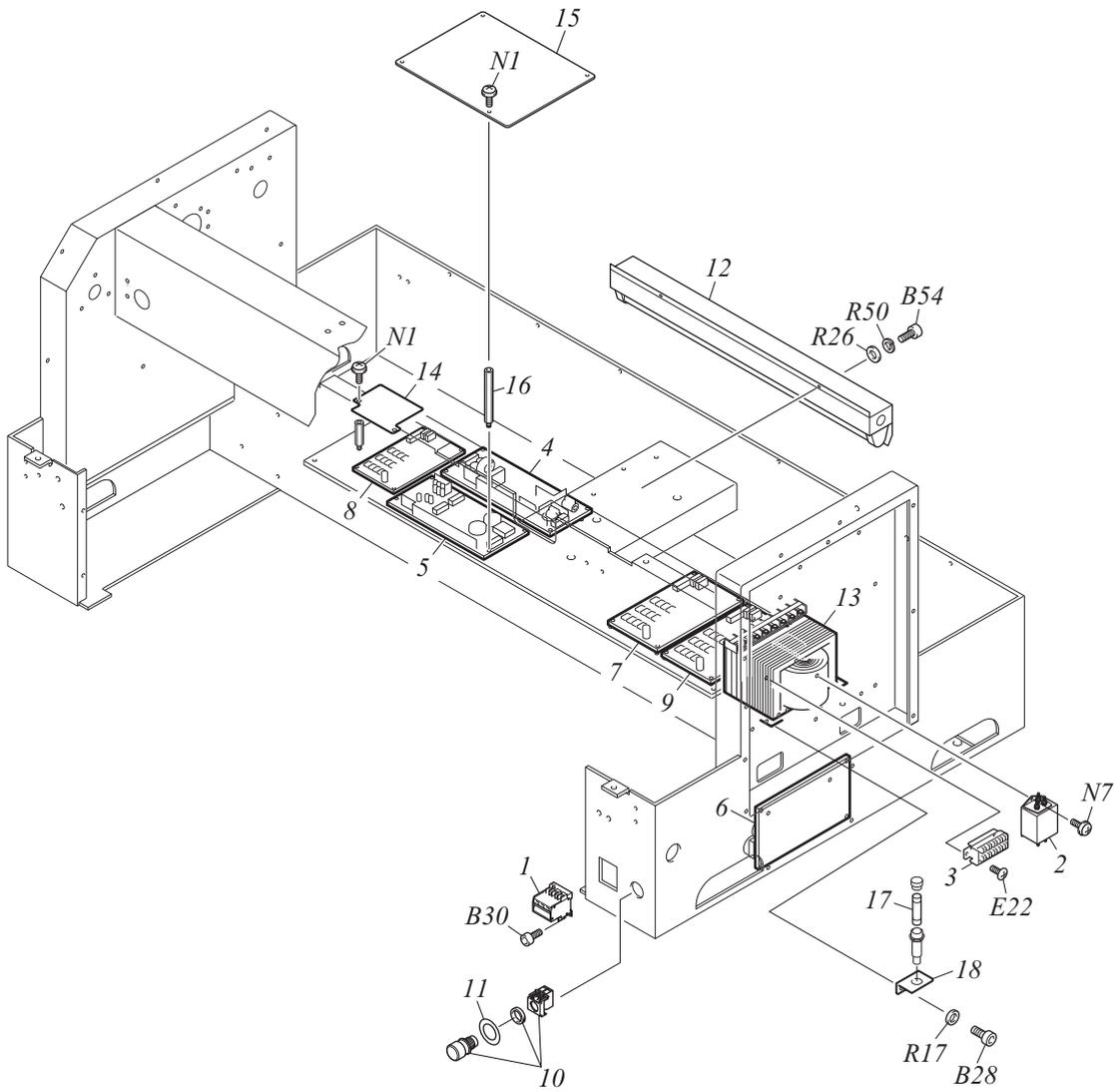

# ELECTRICAL PARTS

MG-13

No.	Part Name	Part No.	Remark
1	CIRCUIT PROTECTOR :SINGLE PHASE 10A	646100100010	
2	NOISE FILTER :SINGLE-PHASE	641400140000	
3	TERMINAL BASE :5P	643400050000	
4	DC POWER SUPPLY :24V	645300191011	
5	DC POWER SUPPLY :5V +/-12V	645300030000	
6	CARD :POWER SUPPLY :SINGLE HEAD	0J2101602030	
7	CARD :MACHINE	0J2502301060	
8	DRIVER :X12-F[A]	0J0302500A30	
9	CARD :HEAD	0J2702301070	
10	SWITCH :EMERGENCY STOP[A]	0J0603000A10	
11	NAME PLATE :EMERGENCY STOP SWITCH	0J5100600000	
12	FLUORESCENT LAMP :1-LAMP 18W :DIRECT MOUNTING[A]	0J0710400A00	Export (Excluding ETL-Spec. and Taiwanese markets)
12	FLUORESCENT LAMP :30W :DIRECT MOUNTING[A]	0J0713600A00	Japanese and Taiwanese markets
13	TRANSFORMER :X12	643100140001	ETL, EN, ENA, GES-Spec.
14	COVER :DRIVER CARD	0J5101000000	
15	COVER :DC POWER SUPPLY	0J5100900000	
16	STUD :NO.1 :M3-70	505103050010	
17	FUSE :250V 10A	642700230000	ETL, EN, ENA, GES-Spec.
18	HOLDER :FUSE	0L2240100000	ETL, EN, ENA, GES-Spec.
19			
20			
21			
22			
23			
24			
25			
26			
27			
28			
29			
30			
31			
32			
33			
34			
35			
36			
37			
38			
39			
40			
41			
42			
43			
44			
45			
46			
47			
48			
49			

UNDER THREAD WINDER (OPTION)

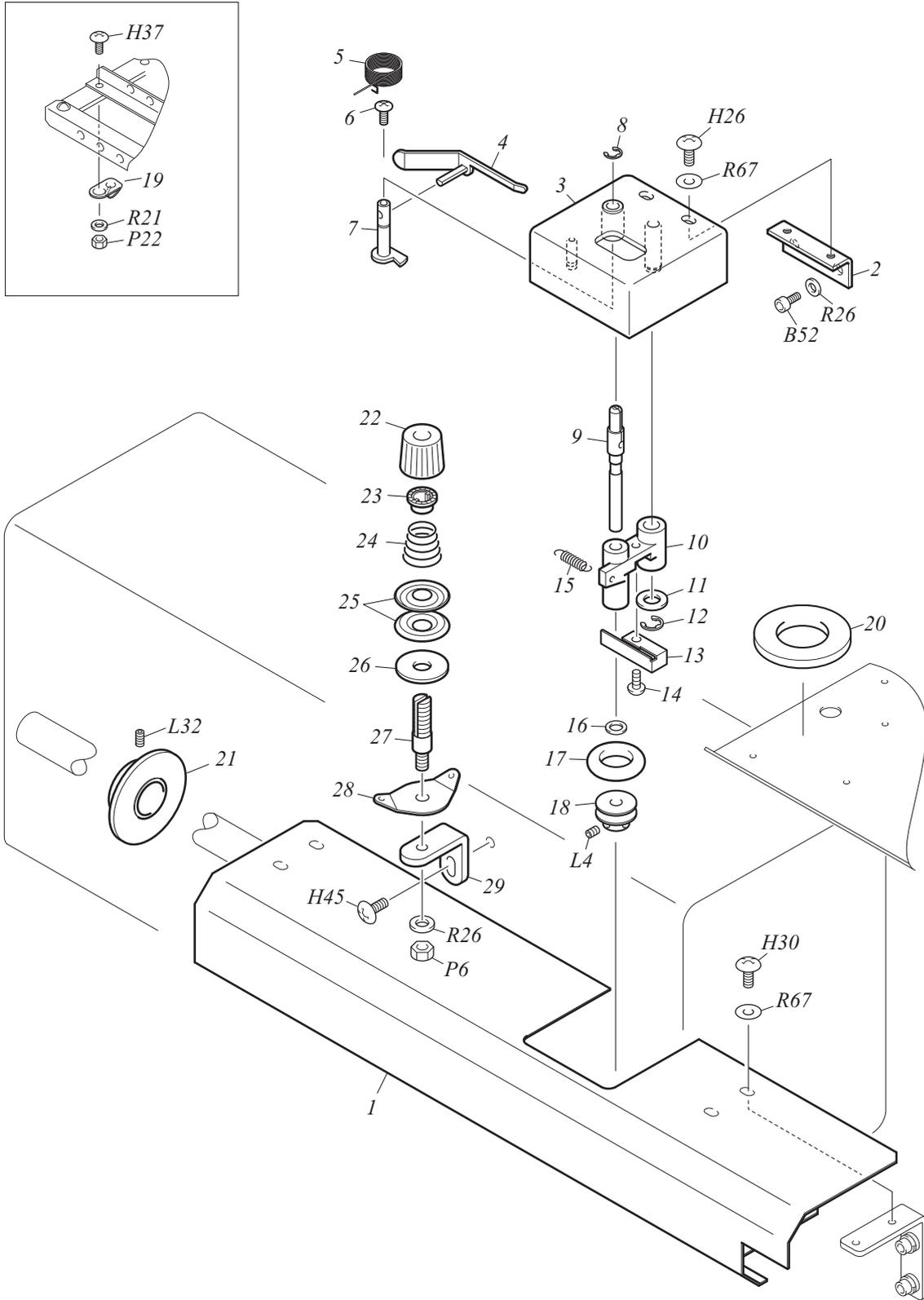

# UNDER THREAD WINDER (OPTION)

MG-14

No.	Part Name	Part No.	Remark
1	SHAFT COVER	0L3140010000	
2	BRACKET :UNDER THREAD WINDER	0L3140020010	
3	BASE :UNDER THREAD WINDER[S]	0L3140030S10	
4	BOBBIN PRESSER[S]	0L3140120S00	
5	TORSION SPRING :0.9MM DIA.	507309060000	
6	PAN HEAD SCREW :9/64*5.5	SA60740552CN	
7	THREAD WINDER CAM SHAFT[S]	0L3140140S00	
8	E-RING :5MM DIA.	611100310000	
9	THREAD WINDER SHAFT	0L3140110000	
10	THREAD WINDER ARM	0L3140130000	
11	PLAIN WASHER :M8*16*T0.8	S301081602SC	
12	E-RING :6MM DIA.	611100320000	
13	THREAD WINDER PLATE SPRING	0L3140150000	
14	PAN HEAD SCREW :11/64*8	SA60750802CN	
15	TENSION SPRING :NO.1 :0.6MM DIA.	507406010000	
16	PLAIN WASHER :M6*10*T0.5	S301061001SC	
17	RUBBER RING	0L3140090000	
18	THREAD WINDER WHEEL	0L3140100000	
19	THREAD GUIDE :NO.2	516202020000	
20	FELT :THREAD STAND PLATE[S]	0D0110050S00	
21	PULLEY :THREAD WINDER[S]	0L3140070S10	
22	KNOB :THREAD TENSION :B	0C0220070000	
23	SPRING HOOK	0C0220080000	
24	TAPER SPRING :1.0MM DIA.	507710020000	
25	TENSION DISK	0C0220120000	
26	FELT PACKING	0C0220040000	
27	THREAD TENSION STUD	0C0220130000	
28	THREAD TENSION GUIDE	0C0220110000	
29	STAY :THREAD GUIDE :B	0L314017B000	
30			
31			
32			
33			
34			
35			
36			
37			
38			
39			
40			
41			
42			
43			
44			
45			
46			
47			
48			
49			
50			

No.	Part No.	Remark	No.	Part No.	Remark
A	Flat Fillister Head Screw		B18	S120031501TN	M3*15
A1	SA41730351CN	1/8*44*3.5	B19	S120031601TN	M3*16
A2	SA41730501CN	1/8*44*5	B20	S120031801TN	M3*18
A3	SA41730551CN	1/8*44*5.5	B21	S120032003TD	M3*20
A4	SA41730601CN	1/8*44*6	B22	S120032001TN	M3*20
A5	SA41740301CN	9/64*40*3	B23	S120032501TN	M3*25
A6	SA41740402CN	9/64*40*4	B24	S120033001TN	M3*30 Half Threads
A7	SA41740401SA	9/64*40*4	B25	S120040501TD	M4*5
A8	SA41740403CL	9/64*40*4	B26	S120040502TN	M4*5
A9	SA41740404CN	9/64*40*4	B27	S120040602TD	M4*6
A10	SA41740501CN	9/64*40*5	B28	S120040601TN	M4*6
A11	SA41740601CN	9/64*40*6	B29	S120040801TD	M4*8
A12	SA41740602CN	9/64*40*6	B30	S120040802TN	M4*8
A13	SA41740701CN	9/64*40*7	B31	S120041001TD	M4*10
A14	SA41740801CN	9/64*40*8	B32	S120041002TN	M4*10
A15	SA41740802CN	9/64*40*8	B33	S120041201TD	M4*12
A16	SA41740803CN	9/64*40*8	B34	S120041202TN	M4*12
A17	SA41741001CN	9/64*40*10	B35	S120041401TN	M4*14
A18	SA41741202CN	9/64*40*12	B36	S120041502TD	M4*15
A19	SA41741501CN	9/64*40*15	B37	S120041501TN	M4*15
A20	SA41750431TN	11/64*40*4.3	B38	S120041601TN	M4*16
A21	SA41750701CN	11/64*40*7	B39	S120041801TN	M4*18
A22	SA41750751CN	11/64*40*7.5	B40	S120042002TD	M4*20
A23	SA41750901SH	11/64*40*9	B41	S120042001TN	M4*20
A24	SA41751151CN	11/64*40*11.5	B42	S120042502TD	M4*25
A25	SA41751201CN	11/64*40*12	B43	S120042501TN	M4*25
A26	S141030801SC	M3*8	B44	S120042504TN	M4*25 Half Threads
A27	S141030802SD	M3*8	B45	S120043001TN	M4*30
A28	S141031001CC	M3*10	B46	S120043502TD	M4*35
A29	S141041001SC	M4*10	B47	S120043501TN	M4*35
			B48	S120044001TN	M4*40
			B49	S120044501TN	M4*45
B	Hexagon Socket Head Cap Screw		B50	S120050601TN	M5*6
B1	S120020801TD	M2*8	B51	S120050801TD	M5*8
B2	S120021001TD	M2*10	B52	S120050802TN	M5*8
B3	S120480501TN	M2.6*5	B53	S120051001TD	M5*10
B4	S120030301TN	M3*3	B54	S120051002TN	M5*10
B5	S120030401TN	M3*4	B55	S120051004TP	M5*10
B6	S120030502TD	M3*5	B56	S120051201TD	M5*12
B7	S120030501TN	M3*5	B57	S120051202TN	M5*12
B8	S120030601TD	M3*6	B58	S120051401TN	M5*14
B9	S120030602TN	M3*6	B59	S120051501MZ	M5*15
B10	S120030804MZ	M3*8	B60	S120051502TD	M5*15
B11	S120030801TD	M3*8	B61	S120051503TN	M5*15
B12	S120030802TN	M3*8	B62	S120051601TN	M5*16
B13	S120031001TD	M3*10	B63	S120051801TN	M5*18
B14	S120031002TN	M3*10	B64	S120052001TD	M5*20
B15	S120031203TD	M3*12	B65	S120052002TN	M5*20
B16	S120031201TN	M3*12	B66	S120052201TN	M5*22
B17	S120031502TD	M3*15	B67	S120052301TN	M5*23

# B.C

No.	Part No.	Remark	No.	Part No.	Remark
B	Hexagon Socket Head	Cap Screw	B117	S120102001TN	M10*20
B68	S120052501TN	M5*25	B118	S120102501TN	M10*25
B69	S120053001TN	M5*30	B119	S120103001TN	M10*30
B70	S120053503TD	M5*35	B120	S120103501TN	M10*35
B71	S120053501TN	M5*35	B121	S120104001TN	M10*40
B72	S120053502TN	M5*35 Half Threads	B122	S120123001TN	M12*30
B73	S120054001TN	M5*40	B123	S120123501TN	M12*35
B74	S120054501TN	M5*45	B124	S120081801TN	M8*18
B75	S120055001TN	M5*50	B125	S120470501TN	M2.5*5
B76	S120055002TN	M5*50 Half Threads	B126	S120052502TD	M5*25
B77	S120055501TN	M5*55	B127	S120030302TD	M3*3
B78	S120056001TN	M5*60	B128	S120051504TN	M5*15 Low Head
B79	S120056003TN	M5*60 Half Threads	B129	S120031801TD	M3*18
B80	S120060801TN	M6*8	B130	S120052801TN	M5*28
B81	S120060901TN	M6*9	B131	S120044502TN	M4*45 Half Threads
B82	S120061001TN	M6*10	B132	S120081501TD	M8*15
B83	S120061202TD	M6*12	B133	S120051802TD	M5*18
B84	S120061201TN	M6*12	B134	S120470401TN	M2.5*4
B85	S120061501TD	M6*15	B135	S120033003SD	M3*30
B86	S120061502TN	M6*15	B136	S120030402TD	M3*4
B87	S120061801TD	M6*18			
B88	S120061802TN	M6*18			
B89	S120062001TN	M6*20			
B90	S120062501TN	M6*25	C	Hexagon Bolt	
B91	S120063001TN	M6*30	C1	S121030601SD	M3*6
B92	S120063501TN	M6*35	C2	S121040801SD	M4*8
B93	S120064001TN	M6*40	C3	S121042501SD	M4*25
B94	S120064501TN	M6*45	C4	S121051001SD	M5*10
B95	S120064502TN	M6*45 Half Threads	C5	S121051502SC	M5*15
B96	S120065001TN	M6*50 Half Threads	C6	S121051501SD	M5*15
B97	S120066501TN	M6*65	C7	S121052001SD	M5*20
B98	S120067501TN	M6*75 Half Threads	C8	S121061501SC	M6*15
B99	S120068001TN	M6*80 Half Threads	C9	S121062501TN	M6*25
B100	S12006A001TN	M6*100	C10	S121064501SD	M6*45
B101	S120081201TN	M8*12	C11	S121065001SC	M6*50
B102	S120081502TN	M8*15	C12	S121065002SD	M6*50
B103	S120081503TP	M8*15	C13	S121065501SD	M6*55
B104	S120081601TN	M8*16	C14	S121066501SD	M6*65
B105	S120082001TN	M8*20	C15	S121067501SC	M6*75
B106	S120082502TN	M8*25	C16	S121081501TN	M8*15
B107	S120083001TN	M8*30	C17	S121081801TN	M8*18
B108	S120083501TN	M8*35	C18	S121103001TN	M10*30
B109	S120084001TN	M8*40	C19	S121103502SC	M10*35
B110	S120084002TN	M8*40 Half Threads	C20	S121103501TN	M10*35
B111	S120084501TN	M8*45	C21	S121104001SC	M10*40
B112	S120084502TN	M8*45 Half Threads	C22	S121125001TN	M12*50
B113	S120085001TN	M8*50	C23	S12112B001TN	M12*110
B114	S120086001TN	M8*60	C24	S121082501TN	M8*25
B115	S120087001TN	M8*70	C25	S121102501TN	M10*25
B116	S120102002TD	M10*20	C26	S121082202TN	M8*22

No.	Part No.	Remark	No.	Part No.	Remark
D	Round Fillister Head Screw		E23	S160030801MZ	M3*8
D1	SA43740401CL	9/64*40*4	E24	S160030803SA	M3*8
D2	SA43740501CL	9/64*40*5	E25	S160030802SD	M3*8
D3	SA43740502CN	9/64*40*5	E26	S160031001MZ	M3*10
D4	SA43740503CN	9/64*40*5	E27	S160031003SC	M3*10 Half Threads
D5	SA43740504CN	9/64*40*5	E28	S160031002SD	M3*10
D6	SA43740601CL	9/64*40*6	E29	S160031101SC	M3*11 Half Threads
D7	SA43740602CN	9/64*40*6	E30	S160031201MZ	M3*12
D8	SA43740603CL	9/64*40*6	E31	S160031202SD	M3*12
D9	SA43740604CN	9/64*40*6	E32	S160031401SA	M3*14
D10	SA43740682CN	9/64*40*6.8	E33	S160031402SD	M3*14
D11	SA43740801CL	9/64*40*8	E34	S160031501SD	M3*15
D12	SA43740802CN	9/64*40*8	E35	S160031601SD	M3*16
D13	SA43741001CN	9/64*40*10	E36	S160031801SD	M3*18
D14	SA43741201CN	9/64*40*12	E37	S160032001SD	M3*20
D15	SA43750601CN	11/64*40*6	E38	S160033001SD	M3*30
D16	SA43750652CN	11/64*40*6.5	E39	S160034001SD	M3*40 Half Threads
D17	SA43751051CN	11/64*40*10.5	E40	S160035001SD	M3*50 Half Threads
D18	SA43751201CN	11/64*40*12	E41	S160040401SD	M4*4
D19	SA43751501CN	11/64*40*15	E42	S160040501SD	M4*5
D20	SA43812451CN	9/32*28*24.5	E43	S160040601MZ	M4*6
D21	S143030501SD	M3*5	E44	S160040602SD	M4*6
			E45	S160040801SD	M4*8
			E46	S160041001SD	M4*10
			E47	S160041201SD	M4*12
			E48	S160041501SD	M4*15
			E49	S160041801SD	M4*18
E	Pan Head Screw		E50	S160043001SD	M4*30
E1	S160410141MZ	M1.4*1.4	E51	S160045001SD	M4*50
E2	S160020202MZ	M2*2	E52	S160046001SD	M4*60
E3	S160020301MZ	M2*3	E53	S160050601SD	M5*6
E4	S160020401MZ	M2*4	E54	S160050701SD	M5*7
E5	S160020801MZ	M2*8	E55	S160050801SD	M5*8
E6	S160470301MZ	M2.5*3	E56	S160051002MZ	M5*10
E7	S160470402MZ	M2.5*4	E57	S160051001SD	M5*10
E8	S160470501MZ	M2.5*5	E58	S160051201SD	M5*12
E9	S160470801MZ	M2.5*8	E59	S160053001SD	M5*12
E10	S160471301MZ	M2.5*13	E60	S160051501SD	M5*15
E11	S160471302SD	M2.5*13	E61	S160054501SD	M5*45
E12	S160480601SD	M2.6*6	E62	S160055001SD	M5*50
E13	S160030301MZ	M3*3	E63	S160056001SD	M5*60
E14	S160030302SD	M3*3	E64	S160047001SD	M4*70
E15	S160030403CD	M3*4	E65	S160480801SD	M2.6*8
E16	S160030401MZ	M3*4	E66	S160030504SC	M3*5
E17	S160030402SD	M3*4	E67	S160480602MZ	M2.6*6
E18	S160030501MZ	M3*5	E68	S160031403MZ	M3*14
E19	S160030502SD	M3*5	E69	S160042001SD	M4*20
E20	S160030601MZ	M3*6	E70	S160044501SD	M4*45
E21	S160030603SA	M3*6	E71	S160020203SD	M2*2
E22	S160030602SD	M3*6	E72	S160470502SD	M2.5*5

# F.G.H

No.	Part No.	Remark	No.	Part No.	Remark
<i>F</i>	Countersunk Head Screw		<i>G</i>	Round Countersunk Head Screw	
<i>F1</i>	SA51741001CN	9/64*40*10	<i>G1</i>	SA53730601CL	1/8*44*6
<i>F2</i>	SA50750801CN	11/64*40*8	<i>G2</i>	SA53740301CL	9/64*40*3
<i>F3</i>	S150020601SD	M2*6	<i>G3</i>	SA53740351CL	9/64*40*3.5
<i>F4</i>	S150030401MZ	M3*4	<i>G4</i>	SA53740401CL	9/64*40*4
<i>F5</i>	S150030402SD	M3*4	<i>G5</i>	SA53740601CL	9/64*40*6
<i>F6</i>	S150030501MZ	M3*5	<i>G6</i>	SA53740701CL	9/64*40*7
<i>F7</i>	S150030502SD	M3*5	<i>G7</i>	SA53740951CL	9/64*40*9.5
<i>F8</i>	S151030601SD	M3*6	<i>G8</i>	SA53741201CL	9/64*40*12
<i>F9</i>	S150030601MZ	M3*6			
<i>F10</i>	S150030602SD	M3*6			
<i>F11</i>	S150030701SD	M3*7			
<i>F12</i>	S151030801SD	M3*8			
<i>F13</i>	S150030801MZ	M3*8			
<i>F14</i>	S150030804SC	M3*8			
<i>F15</i>	S150030802SD	M3*8			
<i>F16</i>	S150030803SN	M3*8	<i>H</i>	Truss Head Screw	
<i>F17</i>	S150031002MZ	M3*10	<i>H1</i>	SA30730701CL	1/8*44*7
<i>F18</i>	S150031001SD	M3*10	<i>H2</i>	SA30740301CL	9/64*40*3.5
<i>F19</i>	S150031201MZ	M3*12	<i>H3</i>	SA30740401CL	9/64*40*4
<i>F20</i>	S150031202SD	M3*12	<i>H4</i>	SA31740401CM	9/64*40*4
<i>F21</i>	S150031501MZ	M3*15	<i>H5</i>	SA30740601CL	9/64*40*6
<i>F22</i>	S150031601SD	M3*16	<i>H6</i>	SA30740801CL	9/64*40*8
<i>F23</i>	S150040501SD	M4*5	<i>H7</i>	S130470301MZ	M2.5*3
<i>F24</i>	S150040602MZ	M4*6	<i>H8</i>	S130470302SD	M2.5*3
<i>F25</i>	S150040601SD	M4*6	<i>H9</i>	S130470401MZ	M2.5*4
<i>F26</i>	S150040801MZ	M4*8	<i>H10</i>	S130470402SA	M2.5*4
<i>F27</i>	S150040802SD	M4*8	<i>H11</i>	S130470403SD	M2.5*4
<i>F28</i>	S150041001MZ	M4*10	<i>H12</i>	S130030301MZ	M3*3
<i>F29</i>	S150041002SD	M4*10	<i>H13</i>	S130030302SD	M3*3
<i>F30</i>	S150041201SD	M4*12	<i>H14</i>	S130030402SD	M3*4
<i>F31</i>	S150041401SD	M4*14	<i>H15</i>	S130030501MZ	M3*5
<i>F32</i>	S150041501SD	M4*15	<i>H16</i>	S130030502SD	M3*5
<i>F33</i>	S150042001SD	M4*20	<i>H17</i>	S130030601MZ	M3*6
<i>F34</i>	S150042201SD	M4*22	<i>H18</i>	S130030602SD	M3*6
<i>F35</i>	S150042501SD	M4*25	<i>H19</i>	S130030603SA	M3*6
<i>F36</i>	S150050601SD	M5*6	<i>H20</i>	S130030802SD	M3*8
<i>F37</i>	S150050801SD	M5*8	<i>H21</i>	S130030803SA	M3*8
<i>F38</i>	S150051001MZ	M5*10	<i>H22</i>	S130031001MZ	M3*10
<i>F39</i>	S150051002SD	M5*10	<i>H23</i>	S130031002SD	M3*10
<i>F40</i>	S150051201SD	M5*12	<i>H24</i>	S130032001SD	M3*20
<i>F41</i>	S150051501SD	M5*15	<i>H25</i>	S130040401MZ	M4*4
<i>F42</i>	S150053001SD	M5*30	<i>H26</i>	S130040402SD	M4*4
<i>F43</i>	S150053501SD	M5*35	<i>H27</i>	S130040501MZ	M4*5
<i>F44</i>	S150054001SD	M5*40	<i>H28</i>	S130040502SD	M4*5
<i>F45</i>	S150061502SC	M6*15	<i>H29</i>	S130040601MZ	M4*6
<i>F46</i>	S150061503SD	M6*15	<i>H30</i>	S130040602SD	M4*6
<i>F47</i>	S150063501SD	M6*35	<i>H31</i>	S130040651SD	M4*6.5
<i>F48</i>	S150081201SD	M8*12	<i>H32</i>	S130040801MZ	M4*8
<i>F49</i>	S150087001TN	M8*70	<i>H33</i>	S130040802SD	M4*8

No.	Part No.	Remark	No.	Part No.	Remark
<i>H</i>	Truss Head Screw		<i>K</i>	Slotted Set Screw	
<i>H34</i>	S130040803MZ	M4*8 JIS	<i>K1</i>	SA71730351CN	1/8*44*3.5
<i>H35</i>	S130041002MZ	M4*10	<i>K2</i>	SA71740601CN	9/64*40*6
<i>H36</i>	S130041001SD	M4*10	<i>K3</i>	SA71750251CN	11/64*40*2.5
<i>H37</i>	S130041201SD	M4*12	<i>K4</i>	SA71750351CN	11/64*40*3.5
<i>H38</i>	S130041502SD	M4*15	<i>K5</i>	SA71750401CN	11/64*40*4
<i>H39</i>	S130042001SD	M4*20	<i>K6</i>	SA71750501CN	11/64*40*5
<i>H40</i>	S130050501SD	M5*5	<i>K7</i>	SA71790501CN	15/64*28*5
<i>H41</i>	S130050602MZ	M5*6	<i>K8</i>	SA71791001CN	15/64*28*10
<i>H42</i>	S130050601SD	M5*6	<i>K9</i>	SA71791501CN	15/64*28*15
<i>H43</i>	S130050651SD	M5*6.5	<i>K10</i>	SA71791701CN	15/64*28*17
<i>H44</i>	S130050701SD	M5*7	<i>K11</i>	SA71800401CN	1/4*40*4
<i>H45</i>	S130050801MZ	M5*8	<i>K12</i>	SA71800451CN	1/4*40*4.5
<i>H46</i>	S130050802SD	M5*8	<i>K13</i>	SA71800501CN	1/4*40*5
<i>H47</i>	S130051002MZ	M5*10	<i>K14</i>	SA71800601CN	1/4*40*6
<i>H48</i>	S130051001SD	M5*10	<i>K15</i>	SA71800801CN	1/4*40*8
<i>H49</i>	S130051201MZ	M5*12	<i>K16</i>	SA71811201CN	9/32*28*12
<i>H50</i>	S130051202SD	M5*12	<i>K17</i>	S171050601TN	M5*6
<i>H51</i>	S130051501SD	M5*15			
<i>H52</i>	S130052001SD	M5*20			
<i>H53</i>	S130052502SD	M5*25			
<i>H54</i>	S130053001SD	M5*30			
<i>H55</i>	S130053501SD	M5*35			
<i>H56</i>	S130060801SD	M6*8	<i>L</i>	Hexagon Socket Head Set Screw	
<i>H57</i>	S130061001SD	M6*10	<i>L1</i>	SA70730251CN	1/8*44*2.5
<i>H58</i>	S130062201SD	M6*22	<i>L2</i>	SA70730301CN	1/8*44*3
<i>H59</i>	S130062501SD	M6*25	<i>L3</i>	SA70750901CN	11/64*28*9
<i>H60</i>	S130063501SD	M6*35	<i>L4</i>	SA70750401CN	11/64*40*4
<i>H61</i>	S130064001SD	M6*40	<i>L5</i>	SA70750601CN	11/64*40*6
<i>H62</i>	S130031501SD	M3*15	<i>L6</i>	SA70750801CN	11/64*40*8
<i>H63</i>	S130043501SD	M4*35	<i>L7</i>	SA70790401CN	15/64*28*4
<i>H64</i>	S130020201SD	M2*2	<i>L8</i>	SA70790901CN	15/64*28*9
<i>H65</i>	S130470501SD	M2.5*5	<i>L9</i>	S170470301TN	M2.5*3
<i>H66</i>	S130052002MZ	M5*20	<i>L10</i>	S170030201TN	M3*2
<i>H67</i>	S130054501SE	M5*45	<i>L11</i>	S170030301TN	M3*3
<i>H68</i>	S130050502MZ	M5*5	<i>L12</i>	S170030401TN	M3*4
<i>H69</i>	S130054001SD	M5*40	<i>L13</i>	S170030501TN	M3*5
<i>H70</i>	S130055001SD	M5*50	<i>L14</i>	S170030601TN	M3*6
			<i>L15</i>	S170030801TN	M3*8
			<i>L16</i>	S170040301TN	M4*3
			<i>L17</i>	S170040401TN	M4*4
			<i>L18</i>	S170040501TN	M4*5
<i>J</i>	Round Head Screw		<i>L19</i>	S170040601TN	M4*6
<i>J1</i>	S162020301MZ	M2*3	<i>L20</i>	S170040602TN	M4*6 Half Threads
<i>J2</i>	S162030801SD	M3*8	<i>L21</i>	S170040801TN	M4*8
<i>J3</i>	S162030802SE	M3*8	<i>L22</i>	S170041001TN	M4*10
<i>J4</i>	S162031001MZ	M3*10	<i>L23</i>	S170041201TN	M4*12
			<i>L24</i>	S170050401TN	M5*4
			<i>L25</i>	S170050501TN	M5*5
			<i>L26</i>	S170050601TN	M5*6

# L.M.N.P

No.	Part No.	Remark	No.	Part No.	Remark
L	Hexagon Socket Head Set Screw		N10	S660041001SE	M4*10
L27	S170050801TN	M5*8	N11	S660041201SE	M4*12
L28	S170051001TN	M5*10	N12	S660045501SE	M4*55
L29	S170051201TN	M5*12	N13	S660051001SE	M5*10
L30	S170051501TN	M5*15	N14	S660051201SE	M5*12
L31	S170060501TN	M6*5	N15	S660051401SE	M5*14
L32	S170060601TN	M6*6	N16	S660051801SE	M5*18
L33	S170060801TN	M6*8	N17	S660030801MZ	M3*8
L34	S170061001TN	M6*10	N18	S660030502MZ	M3*5
L35	S170061801TN	M6*18	N19	S660031502MZ	M3*15
L36	S170080801TN	M8*8			
L37	S170081001TN	M8*10			
L38	S170081501TN	M8*15			
L39	S170031001TN	M3*10			
L40	S170031201TN	M3*12			
L41	S170053001TN	M5*30	P	Nut	
L42	S170061201TN	M6*12	P1	SB10730601CN	1/8*44*6*3
			P2	SB10740601CL	9/64*40*6*2
			P3	SB10740602CN	9/64*40*6*3
			P4	SB10750602CN	11/64*40*6*2
			P5	SB10750603CN	11/64*40*6*3
M	Hexagon Socket Head Button Screw		P6	SB10750701CN	11/64*40*7*3
M1	S124030401SC	M3*4	P7	SB11750701CN	11/64*40*7*3
M2	S124040601SC	M4*6	P8	S210420001XA	M1.6 Type 1
M3	S124040802SC	M4*8	P9	S210020001SD	M2 Type 1
M4	S124040803SD	M4*8	P10	S212020002SD	M2 Type 3
M5	S124051001SC	M5*10	P11	S210460002SD	M2.3 Type 1
M6	S124051002SD	M5*10	P12	S210470001MZ	M2.5 Type 1
M7	S124051501SD	M5*15	P13	S212480001SD	M2.6 Type 3
M8	S124081201SC	M8*12	P14	S210030001MZ	M3 Type 1
M9	S124081202SD	M8*12	P15	S210030002SC	M3 Type 1
M10	S124081501SD	M8*15	P16	S210030003SD	M3 Type 1
M11	S124030501SC	M3*5	P17	S215030001SD	M3 Thumbscrew Type 2
M12	S124030801SC	M3*8	P18	S212030001SC	M3 Type 3
M13	S124030502TC	M3*5	P19	S212030002SD	M3 Type 3
			P20	S212530001SC	M3.5 Type 3
			P21	S210040001SC	M4 Type 1
			P22	S210040002SD	M4 Type 1
			P23	S212040001SC	M4 Type 3
			P24	S212040002SD	M4 Type 3
			P25	S217040001SD	M4 Cap
N	Screw with Washer		P26	S210050001SC	M5 Type 1
N1	S660480601SE	M2.6*6	P27	S210050002SD	M5 Type 1
N2	S660030601SE	M3*6	P28	S212050001SC	M5 Type 3
N3	S660030801SE	M3*8	P29	S212050002SD	M5 Type 3
N4	S660031001SE	M3*10	P30	S217050001SD	M5 Cap
N5	S660031501SE	M3*15	P31	S210060001SC	M6 Type 1
N6	S660031601SE	M3*16	P32	S210060002SC	M6 Type 1 (Left)
N7	S660031801SE	M3*18	P33	S210060003SD	M6 Type 1
N8	S660040601SE	M4*6	P34	S210060004SD	M6 Type 1 (Left)
N9	S660040801SE	M4*8			

No.	Part No.	Remark	No.	Part No.	Remark
P	Nut		R26	S301051202SC	Plain M5*12*t0.8
P35	S212060001SC	M6 Type 3	R27	S301051203SD	Plain M5*12*t0.8
P36	S210080001SC	M8 Type 1	R28	S301061102SC	Plain M6*11*t1.6
P37	S210080002SD	M8 Type 1	R29	S301061151SC	Plain M6*11.5*t0.8
P38	S212080001SC	M8 Type 3	R30	S301061301SC	Plain M6*13*t1.0
P39	S212080002SD	M8 Type 3	R31	S301061302SD	Plain M6*13*t1.0
P40	S210100001SC	M10 Type 1	R32	S301061601SC	Plain M6*16*t1.0
P41	S213100002SD	M10 With Flange	R33	S301081601SD	Plain M8*16*t1.2
P42	S213100003SD	M10 With Disk Spring	R34	S301081801SC	Plain M8*18*t1.6
P43	S210120001SC	M12 Type 1	R35	S301081802SD	Plain M8*18*t1.6
P44	S212120001SC	M12 Type 3	R36	S301081803SC	Plain M8*18*t3.2
P45	S212120002SD	M12 Type 3	R37	S301082201SC	Plain M8*22*t3.2
P46	S210160001SD	M16 Type 1	R38	S301102201SC	Plain M10*22*t1.6
P47	S212160002SC	M16 Type 1	R39	S301102601SC	Plain M10*26*t3.2
P48	S212160001SD	M16 Type 3	R40	S301102602SD	Plain M10*26*t3.2
P49	S210200001SC	M20 Type 1	R41	S301122051SC	Plain M12*20.5*t2
P50	S212470001SC	M2.5 Type 3	R42	S301163201SD	Plain M16*32*t2.5
P51	SB12750701SC	11/64*7*2.2 Type 3	R43	S402020001KD	Spring M2
P52	S211040001SD	M4 Type 2	R44	S402480001KC	Spring M2.6
P53	SB12740601MZ	9/64*6*2 Type 3	R45	S402030001KC	Spring M3
P54	SB10750601CN	11/64*6*2.2	R46	S402030002KD	Spring M3
			R47	S402530001KC	Spring M3.5
			R48	S402040001KC	Spring M4
			R49	S402040002KD	Spring M4
R	Washer		R50	S402050001KC	Spring M5
R1	S301410301MZ	Plain M1.4*3*t0.3	R51	S402050002KD	Spring M5
R2	S301020351XZ	Plain M2*3.5*t0.5	R52	S402050003MZ	Spring M5
R3	S301020431SD	Plain M2*4.3*t0.3	R53	S402060001KC	Spring M6
R4	S301480501XB	Plain M2.6*5*t0.5	R54	S402060002KD	Spring M6
R5	S301480751XB	Plain M2.6*7.5*t0.5	R55	S402080001KC	Spring M8
R6	S301030602XZ	Plain M3*6*t0.3	R56	S402080002KD	Spring M8
R7	S301030603SC	Plain M3*6*t0.5	R57	S402100001KC	Spring M10
R8	S301030601SD	Plain M3*6*t0.5	R58	S402100002KD	Spring M10
R9	S301030701SD	Plain M3*7*t0.5	R59	S402120001KC	Spring M12
R10	S301030804SD	Plain M3*8*t0.3	R60	S305041101TP	Wave M4
R11	S301030805MZ	Plain M3*8*t0.5	R61	S305051001TN	Wave M5
R12	S301030801SC	Plain M3*8*t0.5	R62	S305061051TN	Wave M6
R13	S301030802SD	Plain M3*8*t0.5	R63	S304040851TP	With teeth M4
R14	S301030803SD	Plain M3*8*t1	R64	S304051001TP	With teeth M5
R15	S301040805SC	Plain M4*8*t0.5	R65	S306080001SC	Slant M8
R16	S301040802SD	Plain M4*8*t0.5	R66	S303040801SC	Disk Spring M4
R17	S301040804SC	Plain M4*8*t0.8	R67	S301040901EZ	Plain M4*9*t0.3
R18	S301040803SD	Plain M4*8*t0.8	R68	S301470252MZ	Plain M2.5*5*t0.5
R19	S301041004MZ	Plain M4*10*t0.8	R69	S301030605SD	Plain M3*6*t1.0
R20	S301041002SC	Plain M4*10*t0.8	R70	S301030604MZ	Plain M3*6*t0.5
R21	S301041003SD	Plain M4*10*t0.8	R71	S305051101TN	Wave M5
R22	S301041201SC	Plain M4*12*t1	R72	S301470253SD	Plain M2.5*5*t0.5
R23	S301051002SC	Plain M5*10*t0.8	R73	S301470251SC	Plain M2.5*5*t0.5
R24	S301051003SD	Plain M5*10*t0.8			
R25	S301051204MZ	Plain M5*12*t0.8			

**1st Edition    January, 2005**

**3rd Edition    May, 2011**

■ **Manufactured by:**

**Tokai Industrial Sewing Machine Co., Ltd.**

NO.1800, Ushiyama-cho, Kasugai, Aichi-pref., 486-0901, Japan  
Telephone:568-33-1161 Fax:568-33-1191

■ **Distributed by:**

**Tajima Industries Ltd.**

19-22, Shirakabe, 3-chome, Higashi-ku, Nagoya, 461-0011, Japan  
Telephone:52-932-3444 Fax:52-932-2457

■ **Authorized Distributor:**

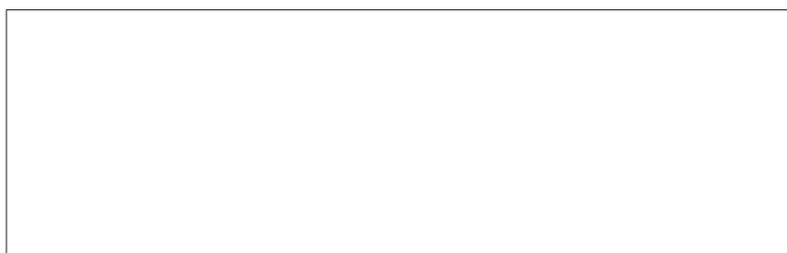

●Copy, reprint, or reform of a part or whole of this manual without permission is prohibited.

## ***THE TAJIMA GROUP***

<http://www.tajima.com>

### **Tajima Industries Ltd.**

19-22, Shirakabe, 3-chome, Higashi-ku, Nagoya, 461-0011, JAPAN  
TEL.81-52-932-3811 FAX.81-52-932-3815

### **Tokai Industrial Sewing Machine Co.,Ltd.**

NO.1800, Ushiyama-cho, Kasugai, Aichi-pref., 486-0901, JAPAN  
TEL.81-568-33-1161 FAX.81-568-33-1191